

# Converting

**INSIGHTS**

FEBRUARY 2009

## IN THIS ISSUE:

THINK Pre-Owned in 2009. . . . . 1  
 Specials . . . . . 2  
 Webtron Replacement Parts . . . . . 3  
 Equipment Spotlight . . . . . 4  
 Equipment Listings . . . . . 5-13  
 Shimpo DT-329 . . . . . 14  
 Press Room Accessories . . . . . 14  
 Press Room Supplies . . . . . 15  
 Production Accessories . . . . . 16  
 Replacement Parts . . . . . 17  
 Converting Technology . . . . . 18  
 Roll Lifting Equipment . . . . . 19  
 Equipment Spotlight. . . . . Back Cover

## BONUS BUY

**Proven consistency at an economically sound price!**



**ALL ROLLS 18" WIDE X 25 YARDS**

**Sure-TAC 15 mil med density**  
 #K4115 **NOW: \$235.00 per roll**

**Sure-TAC 20 mil med density**  
 #K4120 **NOW: \$310.00 per roll**

## Think... PRE-OWNED IN 2009

Over the years we have seen so many converters build their businesses by investing in high quality pre-owned equipment. There are those that believe buying pre-owned equipment means that you are buying someone else's problems. While this may be true in a small number of cases, more than 95% of the buyers we surveyed feel they have purchased the right piece of equipment at the right price when buying used.

The used equipment buyer is a savvy individual that pays close attention to detail and relies heavily on the experience and honesty of their Dealer. AAA Press has been consulting converters purchasing pre-owned equipment for over 22 years. Our technical experience numbers more than 70 years combined experience and our hands on buying process allows converters to rely on this experience to guide them in to making the right used equipment choice. We have a firm grasp on the fair market value of used equipment including presses, slitters, pre-press, UV's and so much more.

The current economic conditions indicate a buyers market and are indeed excellent motivation to explore a used equipment purchase. Our current pre-owned offering includes over 200 pieces of equipment from high-end manufacturers at outstanding prices. The bottom line is that many converters are finding excellent "turn-key" values that require little more than moving the press to their location. Others opt in for saving of 30-50% off typical used equipment prices by buying presses that require slight modification or minor press rebuilds of which AAA Press is more than capable of providing.

Give-it-a-whirl...take some time to re-evaluate your needs and consider the value and financial reward when buying used equipment. Our knowledgeable inside and outside equipment consultants are here to assist you in the process ensuring both quality and value. Contact your rep today at **800-678-7222**



**LIKE-NEW**  
 Mark Andy 2200 13" 10-color Press... Loaded.

## Contact Us

AAA Press International, Inc.  
 3160 N. Kennicott Avenue  
 Arlington Heights, IL 60004

[www.aaapress.com](http://www.aaapress.com)

### US & Canada

Toll Free: + 1 800 678 7222  
 Telephone: + 1 847 818 1100  
 Fax: + 1 800 678 7983  
[info@aaapress.com](mailto:info@aaapress.com)

### International

Telephone: + 1 847 818 1100  
 Fax: + 1 847 818 0071  
[info@aaapress.com](mailto:info@aaapress.com)

The Dependable One Stop Complete Flexo Shop



# PECIALS

**WHILE IN-STOCK SUPPLIES LAST!**



#AD-800

**Airdale Dryer - 8"**  
 Was: \$1,000.00      **NOW: \$940.00**



#TSC-100

**Tint Sleeve Cutter - 3"**  
 Was: \$1,040.00      **NOW: \$936.00**



#UF-9250-7875

**Ultraflex Dr Blades (plastic) - lots of 100**  
 Was: \$2.50 each      **NOW: \$1.50 each**

## WEBTRON PARTS

**Limited to in-stock quantities.**

PARTS #	DESCRIPTION	QTY	LIST PRICE	SPECIAL
#52-4013	N25 Overloads	5	<del>\$45.00</del>	<b>\$13.00</b>
#6304	Impression Roll - Webtron 650 - Cantilever - 1/8 - 63T & 32DP	4	<del>\$205.00</del>	<b>\$264.00</b>
#6337	Combo Gear Spacer - Impression Shaft	2	<del>\$50.00</del>	<b>\$45.00</b>
#6356	Impression Shaft Assy - Combo Gearing	2	<del>\$550.00</del>	<b>\$425.00</b>
#6361	Gear - Impression Roll - Web 650/750 - "J" Gearing	16	<del>\$148.00</del>	<b>\$115.00</b>
#6446	Register Adjust Screw Collar #6447	9	<del>\$50.00</del>	<b>\$45.00</b>
#6469	Ink Fountain - Webtron 650 OBS - With Hood	2	<del>\$414.00</del>	<b>\$370.00</b>
#6783	Extension Block - 15" - Sheeter Station - In Board	2	<del>\$45.00</del>	<b>\$40.00</b>
#6797	Gear - RBR - Webtron 650/750 - 1/16CP - 128 Teeth - "I" Gearing	6	<del>\$164.00</del>	<b>\$130.00</b>
#6799	Gear - RBR - Webtron 650/750 - 1/8CP - 128 Teeth - CC1	9	<del>\$95.00</del>	<b>\$74.00</b>
#6802	Backup Plate - Dryer Hood - Webtron 650	17	<del>\$104.00</del>	<b>\$83.00</b>
#6904	Idler - Die Station - Webtron 650 - 1"	4	<del>\$113.00</del>	<b>\$95.00</b>
#7028	Sprocket - Waste Capstan Clutch	3	<del>\$80.00</del>	<b>\$45.00</b>
#7042	Clutch Cover - Double Waste Rewind	3	<del>\$250.00</del>	<b>\$195.00</b>
#7129	Pulley - Lamination Station	3	<del>\$30.00</del>	<b>\$20.00</b>
#7135	Bearing Holder - Lamination Station	5	<del>\$125.00</del>	<b>\$90.00</b>
#7136	Retaining Disc - Lamination Station	5	<del>\$107.00</del>	<b>\$85.00</b>
#7138	Spacer - Laminating Tower	1	<del>\$17.00</del>	<b>\$15.00</b>
#7210	Backup Plate - Lower Stacker ASSY	1	<del>\$73.00</del>	<b>\$66.00</b>
#7214	Side Plate - Inboard - Webtron 650 Stacker	2	<del>\$710.00</del>	<b>\$639.00</b>
#7219	Slide Guide - Stacker ASSY	5	<del>\$39.00</del>	<b>\$35.00</b>
#7255	Gib - Inboard - Stacker ASSY	1	<del>\$107.00</del>	<b>\$96.00</b>

# Replacement Parts

for your Webtron®



At AAA Press International, we understand your need for reliable replacement parts that meet and exceed OEM specification, at economical prices.

We are the technical expert in all aspects of Webtron presses, including accurate parts assessment for conversions, along with retrofits for custom and proprietary applications.

## Gauges



#64-4001 60# Slitter **Now: \$31.00**  
 #60-4003 30# Waste / Product **Now: \$69.00**

## Pull Roll Shaft

For exit Nip roll.



#6704 Webtron 650 **Now: \$165.00**  
 #201-0178 Webtom 750 **Now: \$229.00**

## Stacker Belts

Set of 9 belts each.



#71-4007 Short **Now: \$60.00**  
 #71-4008 Long **Now: \$83.00**

## Retainer Collar

For print cylinder shaft.



#201-2824 **Now: \$14.00**

## Die Cut Bridge



#6917 Webtron 650 **Now: \$160.00**  
 #301-0109 Webtom 750 **Now: \$249.00**

## MINI Outboard Support

Convert cantilever print station on your Webtron 650.



#53-0111 **Now: \$255.00**

## QC Anilox Assembly

Generation 3 design.



#A-402-2725-HD-3 **Now: \$595.00**

## Die Bearing Holder



#A-6960 Webtron 650 **Now: \$320.00**  
 #A-201-0181 Webtron 750 **Now: \$295.00**

## Disposable Ink Fountains

50 per case with hose.



#W6503H Webtron 650 **Now: \$110.00**  
 #W7503H Webtron 750 **Now: \$159.00**

## Impression Roll Gears



#9952 "A" gear **Now: \$31.00**  
 #A-C "C" gear **Now: \$34.00**  
 #A-CB 32 P gear **Now: \$40.00**

## Standard Clutch Bearings



#A-CB-1000-Centilever **Now: \$107.00**  
 #A-CB-1000-OBS **Now: \$122.00**  
 #A-CB-1000-HQV **Now: \$132.00**

## OUR SERVICE DEPARTMENT IS AT YOUR SERVICE!

Preventative Maintenance ■ Emergency Repairs ■ Semi and Annual Visits ■ Complete Rebuilding

REPLACEMENT PARTS DISCOUNT WITH SERVICE CONTRACT CALL: **800.678.7222 OR 847.818.1100**



## Aquaflex Prestige / 9-color

2001, Width: 20.5", 1/8 Gearing, 24" Print Repeat, 2 Stork Rotary Screen Units, 7 Chill Rolls, Automatic Throws / Constant Turn Anilox Rolls, 9 Quick Change Anilox Assemblies, 9 Dr. Blade Assemblies, 1 Product Rewind, 30" Rewind Diameter, 1 Waste Rewind, 1 Die Station, 2 Laminators, 2 Electronic Edge Guides, 8 Single-Lamp UV Units, 7 Motorized Registration Units, Hot Foil Stamping, Anilox Rolls, Plate Cylinders, Can see in Operation. Runs 1/2 mil Poly upto standard PS label stock! Includes corona treater, motorized infeed and exit stations, 2 Web Guides, 14 Extra Print Cassettes, Crane System. Does NOT include Unwind Stand (currently a butt splicer). Over \$1.5 Million New!

[Listing #10513](#)



## Arpeco Tracker Premier / Slitter / Rewinder

1999, Width: 13", Electric Edge Guide, Shear Cut Slitting, 1 Product Unwind, 3" Unwind Core Diameter, 30" Unwind Diameter, 1 Product Rewind, 3" Rewind Core Diameter, 18" Rewind Diameter, Strobe Light, 10" Incremental Length Counter, Individual Label Counter, Missing Label Detector, Flag Detector, Splice Detector, 935 Maximum Speed, Labels In / Labels Out, Quad Torch Rewind, Web Advance, 230VAC/3Ph/30A. Can see in Operation.

[Listing #20222](#)

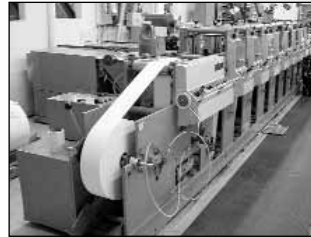

## Mark Andy 4120 / 8-color

1986, Width: 10", 1/8 Gearing, Automatic Throws / Constant Turn Anilox Rolls, Dr. Blade Assembly, 1 Product Rewind, 2 Waste Rewinds, 40" Unwind Diameter, 5 Die Stations, 5 Removable Base Rolls, 1 Sheeting Station, 1 Laminator, 1 Hydraulic Edge Guide, 1 Stacker, 1 Aetek 400-WPI Single-Lamp UV Unit, 13 Motorized Registration Units, Approx. 8 Ceramic Anilox Rolls, Can see in Operation.

[Listing #10610](#)



## Rotoflex - DLI 330 Vericut Config 1 / Diecutter

2007, Width: 13", Electric Edge Guide, Shear Cut Slitting, Underscoring Unit, 2 Die Stations, 19" Die Station Repeat, 3" Unwind Core Diameter, 28" Unwind Diameter, 1 Product Rewind, 3" Rewind Core Diameter, 20" Rewind Diameter, 1 Waste Rewind, 28" Waste Rewind Diameter, 1 Laminating Unwind, Individual Label Counter, 300 Maximum Speed, 2 Servo Die Stations - includes one mag die cylinder. One Flood Coating Station with UV / IR Dryer. One Conveyor Stacker. Maximum speed 300 coating and 140 die cutting. Purchased new in 2007 for \$220,000.00.

[Listing #20224](#)



## Kelleigh 310 / Rotary Plate Maker

Length: 24", Width: 30", Flexo, Exposure, Solvent Washout, Dryer, 3 Drying Drawers.

[Listing #30080](#)



## Arsoma IMC - TR 450 / Turret

1989, Width: 17", 3" Rewind Core Diameter, 5 Turret Rewind Spindles, Hot Melt Core Glueing, Auto Core Eject, Air Coreholders, Encoder assembly for press speed reference.

[Listing #20219](#)



## Web Techniques WT-25 / Table Top Rewinder

2005, Width: 7", 3" OD mechanical unwind core holder, 3" OD neumatic rewind coreholder, slitter assembly, 2 razor knife slitting blades.

[Listing #50293](#)

## PRESSES

**Mark Andy 810 3-color** Listing #10027  
1975, Width: 7", 32 DP Gearing, 2 Product Rewinds, 1 Waste Rewind, 3 Die Stations, and Can be seen in operation.

**Mark Andy 820 3-color** Listing #10618  
1985, Width: 7", 1/8" Gearing, 15" Print Repeat, 2 Product Rewinds, 1 Waste Rewind, 2 Die Stations, 2 Removable Base Rolls, 1 Sheeting Station, 1 Laminator, 1 Stacker, Approx. 3 Ceramic Anilox Rolls, Approx. 100 Plate Cylinders, 230 VAC/36Amps.

**Mark Andy 830 3-color** Listing #10627  
1986, Automatic Throws / Constant Turn Anilox Rolls, 2 Product Rewinds, 1 Waste Rewind, 2 Die Stations, 15,000" Die Repeat, 2 Removable Base Rolls, 1 Sheeting Station, Underscoring Unit, 1 Electronic Edge Guide, 1 Stacker, Can see in Operation. 30" OD Unwind Stand with Dancer controlled tension, Additional 1" OD rewind coreholder.

**Mark Andy 2200-E 6-color** Listing #10634  
1996, Width: 10", 1/8" Gearing, 24" Print Repeat, Automatic Throws / Constant Turn Anilox Rolls, 6 Quick Change Anilox Assemblies, 2 Product Rewinds, 24" Rewind Diameter, 2 Waste Rewinds, 40" Unwind Diameter, 2 Die Stations, 1 Removable Base Roll, 1 Sheeting Station, Underscoring Unit, 1 Electronic Edge Guide, 1 Turn-bar, 1 Stacker, 1 400-WPI Single-Lamp UV Unit, 1 Strobe Light, Approx. 6 Ceramic Anilox Rolls, Can see in Operation. Available December 2008. (1) Delam/Relam Unit, Enercon TL-Max Corona Treating System, (2) Upgraded Dryer Packs, (1) MA Fan Folder Power Take-off. Serviced By MA Certified Techs on a PM program!

**Mark Andy 4120 6-color** Listing #10626  
1976, Width: 10", 1/8" Gearing, Automatic Throws / Constant Turn Anilox Rolls, 2 Product Rewinds, 1 Waste Rewind, 36" Unwind Diameter, 3 Die Stations, 1 Sheeting Station, 1 Hydraulic Edge Guide, 1 Turn-bar, 1 Video Web Inspection System, Can see in Operation. 2 Dryer Packs, New Drive & Upgraded Tension System.

**Mark Andy 4120 8-color** Listing #10610  
1986, Width: 10", 1/8" Gearing, Automatic Throws / Constant Turn Anilox Rolls, Dr. Blade Assembly, 1 Product Rewind, 2 Waste Rewinds, 40" Unwind Diameter, 5 Die Stations, 5 Removable Base Rolls, 1 Sheeting Station, 1 Laminator, 1 Hydraulic Edge Guide, 1 Stacker, 1 Aetek 400-WPI Single-Lamp UV Unit, 13 Motorized Registration Units, Approx. 8 Ceramic Anilox Rolls, Can see in Operation.

**Mark Andy Rotary Letterpress 4300 6-color** Listing #10590  
1984, Width: 10", 2 Product Rewinds, 2 Waste Rewinds, 4 Die Stations, 1 Sheeting Station, 1 Laminator, Anilox Rolls, Air Lift Roll Loader.

**Mark Andy 4300 Letterpress 7-color** Listing #10592  
1982, Width: 10", 1/8" Gearing, 2 Product Rewinds, 40" Rewind Diameter, 2 Waste Rewinds, 3 Die Stations, 1 Removable Base Roll, 1 Sheeting Station, 1 Laminator, 1 Edge Guide, 1 Turn-bar, 1 Stacker, 7 Single-Lamp UV Units, Can see in Operation. Manuals available, 420 Cylinders, Water Wash Plates Machine.

**Mark Andy 2200 10-color** Listing #10644  
2005, Width: 13", 1/8" Gearing, 24" Print Repeat, Automatic Throws / Constant Turn Anilox Rolls, 10 Quick Change Anilox Assemblies, 10 Dr. Blade Assemblies, 2 Product Rewinds, 40" Rewind Diameter, 2 Waste Rewinds, 1 Unwind, 40" Unwind Diameter, 2 Die Stations, 24,000" Die Repeat, 3 Removable Base Rolls, 1 Sheeting Station, 1 Laminator, 1 Electronic Edge Guide, 1 Turn-bar, 1 UVT 400-WPI Single-Lamp UV Unit, 1 Video Web Inspection System, Cold Foil Stamping, Approx. 11 Ceramic Anilox Rolls, Approx. 183 Plate Cylinders, Can see in Operation. MINT CONDITION... LIKE NEW with 9 Infra-red Dryers, integrated roll lifter, integrated die lifter, (2) Hydrjack die pressure gauges, & all exhaust ducting.

**Webtron 750 0-color** Listing #10397  
Width: 7.5", 1/8" Gearing, 2 Product Rewinds, 2 Waste Rewinds, 9 Die Stations, 9 Removable Base Rolls, 1 Sheeting Station, Laminator/Die cutter, unwind stand with web guide & dover closed loop infeed tension unit, (1) infeed laminating station w/Dover closed loop tension control, (1) outfeed laminating station w/Dover closed loop tension control, crush cut slitting, electronic counter.

**Webtron Dart 0-color** Listing #10286  
Width: 6.5", 32 DP Gearing, 1 Product Rewind, 1 Waste Rewind, 2 Die Stations, 1 Edge Guide, Can see in Operation. Solid state drive & larger motor.

**Webtron Super Dart 1-color** Listing #10048  
Width: 6.5", 1/8" Gearing, 1 Product Rewind, 1 Waste Rewind, 2 Die Stations, 2

Removable Base Rolls, Edge guide, and 4-Way heads.

**Webtron 650 2-color** Listing #10585  
1973, Width: 6.5", 32DP Gearing, Webtron OBS, 2 Product Rewinds, 1 Waste Rewind, 2 Die Stations, 1 Sheeting Station, 1 Laminator, 4 Way Bridges.

**Webtron 650 Hightop 3-color** Listing #10614  
1968, Width: 6.5", 1/8" Gearing, Automatic Throws / Constant Turn Anilox Rolls, 3 Webtron 4-Way Heads, 3 Webtron OBS, 2 Product Rewinds, 2 Waste Rewinds, 3 Die Stations, 1 Sheeting Station, 1 Laminator, 1 Hydraulic Edge Guide, Can see in Operation.

**Webtron 7000 3-color** Listing #10617  
Width: 7", 1/8" Gearing, 15" Print Repeat, Automatic Throws / Constant Turn Anilox Rolls, 1 Product Rewind, 1 Waste Rewind, 2 Die Stations, 15,000" Die Repeat, 3 Removable Base Rolls, 1 Sheeting Station, 1 Laminator, 1 Edge Guide, Approx. 3 Chrome Anilox Rolls, 230VAC/3Ph/60Hz/80Amps.

**Webtron 650 4-color** Listing #10643  
Width: 6.5", 1/8" 63T Gearing, Automatic Throws / Constant Turn Anilox Rolls, 4 Mini OBS, 2 Product Rewinds, 1 Waste Rewind, 1 Unwind, 30" Unwind Diameter, 3 Die Stations, 4 Removable Base Rolls, 1 Sheeting Station, 1 Laminator, 1 Hydraulic Edge Guide, Spiral-bevel, helical line shaft gearing.

**Webtron 650 4-color** Listing #10586  
1969, Width: 6.5", 32 DP Gearing, Webtron OBS, 1 Product Rewind, 1 Waste Rewind, 3 Die Stations, 1 Sheeting Station, 1 Laminator, 1 2002 Aetek Single-Lamp UV Unit, Press rebuilt in 2002, Second GWD Web Guide, 4 Way Bridges.

**Webtron 650 4-color** Listing #10587  
1968, Width: 6.5", 32 DP Gearing, Webtron OBS, 2 Product Rewinds, 2 Waste Rewinds, 3 Die Stations, 1 Sheeting Station, 1 Brewer Single-Lamp UV Unit, 4 Way Bridges.

**Webtron 650 4-color** Listing #10374  
Width: 6.5", 32 DP Gearing, 2 Product Rewinds, 3 Die Stations, Edge Guide, Fife P25 Edge guide system, 30" Unwind stands, and 3 Laminating towers with tension control. All printing stations are non-operational!

## RL-1000 Portable Roll Lifter



### FEATURE:

- Extendable legs for different roll widths and loading positions
- Durable roller-ball boom with safety pin for loading, unloading & transporting rolls
- Zero-turn radius for maneuvering rolls in tight places
- Automatic safety brake on boom carriage
- Reversible crank-style winch with automatic load brake
- All steel construction for longevity and worry-free operation



Equipment

**AAA Press International, Inc.**

... for all your printing equipment needs.

Toll Free: + 1 800 678 7222 Telephone: + 1 847 818 1100

## PRESSES CONTINUED

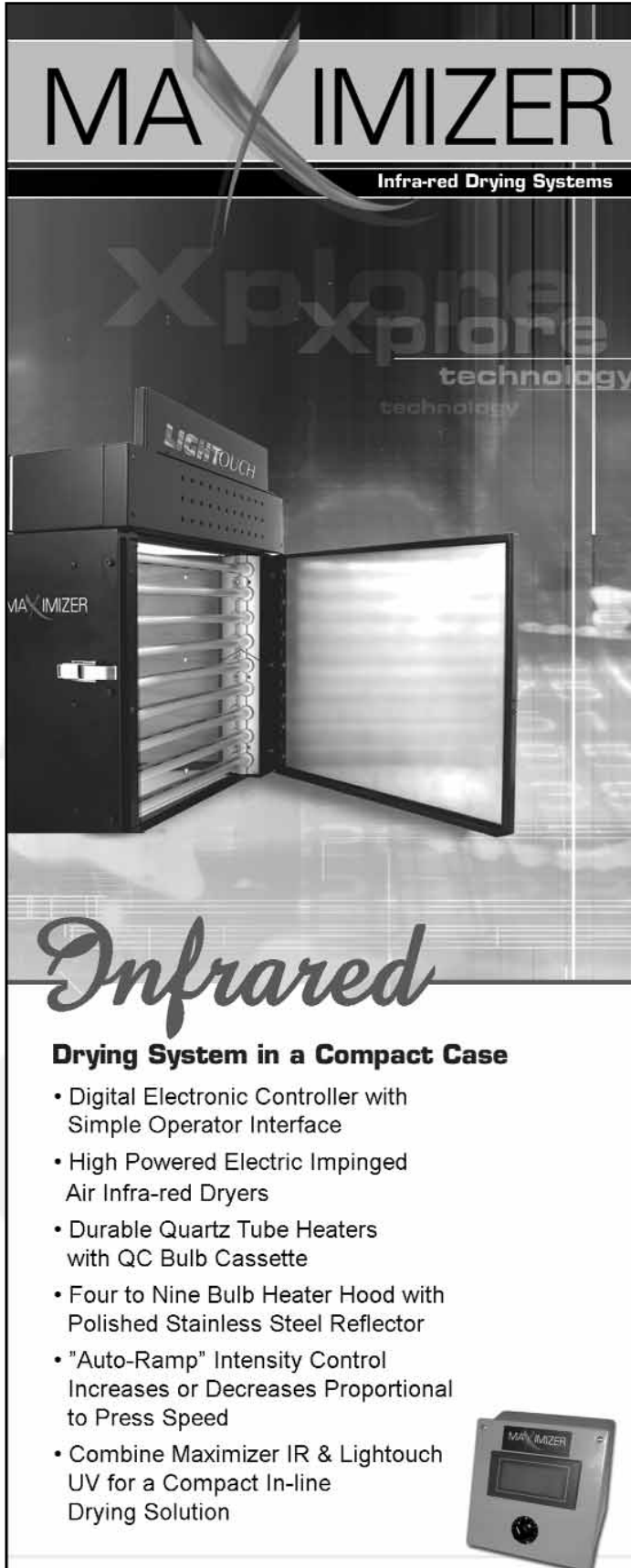

**MAXIMIZER**  
Infra-red Drying Systems

*Infrared*

**Drying System in a Compact Case**

- Digital Electronic Controller with Simple Operator Interface
- High Powered Electric Impinged Air Infra-red Dryers
- Durable Quartz Tube Heaters with QC Bulb Cassette
- Four to Nine Bulb Heater Hood with Polished Stainless Steel Reflector
- "Auto-Ramp" Intensity Control Increases or Decreases Proportional to Press Speed
- Combine Maximizer IR & Lighttouch UV for a Compact In-line Drying Solution



**Webtron 650 4-color** **Listing #10059**  
Width: 6.5", 1/8 Gearing, 2 Product Rewinds, 1 Waste Rewind, 3 Die stations, Sheeting station, Laminator, Edge guide, Webtron OBS, and Webtron 4-way print heads.

**Webtron 650 4-color** **Listing #10058**  
Width: 6.5", 32DP Gearing, 1 Product Rewind, 1 Waste Rewind, 3 Die stations, Sheeting station, Laminator, and Edge guide.

**Webtron 1000 4-color** **Listing #10620**  
1988, Width: 10", 1/8 Gearing, Automatic Throws / Constant Turn Anilox Rolls, 3 Dr. Blade Assemblies, 1 Product Rewind, 1 Waste Rewind, 2 Die Stations, 1 Sheeting Station, 1 Hydraulic Edge Guide, 1 Turn-bar, 8 Motorized Registration Units, M/F Rotary Punch Unit, Approx. 5 Ceramic Anilox Rolls, Bunch Fan Folder, (1) Set of Web 650 die adapters, die hoist.

**Webtron 650 5-color** **Listing #10588**  
1981, Width: 6.5", 1/8 Gearing, Webtron OBS, 2 Product Rewinds, 2 Waste Rewinds, 3 Die Stations, 1 Sheeting Station, 1 Laminator, 1 1993 Aetek Single-Lamp UV Unit, 4 Way Bridges.

**Webtron 650 5-color** **Listing #10556**  
1975, Width: 6.5", 32DP Gearing, Automatic Throws / Constant Turn Anilox Rolls, Dr. Blade Assembly, Webtron 4-Way Heads, 2 Product Rewinds, 40" Rewind Diameter, 2 Waste Rewinds, 40" Unwind Diameter, 4 Die Stations, 4 Removable Base Rolls, 1 Sheeting Station, 1 Laminator, 1 Edge Guide, Can see in Operation. RD Score Unit.

**Webtron 650 5-color** **Listing #10530**  
1976, Width: 6.5", 1/8 Gearing, Automatic Throws / Constant Turn Anilox Rolls, Webtron 4-Way Heads, Webtron OBS, 1 Product Rewind, 30" Rewind Diameter, 1 Waste Rewind, 30" Unwind Diameter, 4 Die Stations, 4 Removable Base Rolls, 1 Laminator, 1 Edge Guide.

**Webtron 650 5-color** **Listing #10479**  
1988, Width: 6.5", 0.125 Gearing, Automatic Throws / Constant Turn Anilox Rolls, 1 Die Station, Can see in Operation. Edge Guide, Turn Bar, Ink Pumps, UV Curing System, Manuals available, unwind/cutting Die Rolls.

**Webtron 650 5-color** **Listing #10291**  
1976, Width: 6.5", 32 DP Gearing, 12" Print Repeat, Auto Throws / Constant Turn Anilox Rolls, Webtron 4-Way Heads, Webtron OBS, 2 Product Rewind, 30" Rewind Diameter, 2 Waste Rewinds, 30" Unwind Diameter, 4 Die Stations, 5 Removable Base Rolls, Sheeting Station, Laminator, Edge Guide, Stacker, 1 Single-Lamp UV Unit, and Can be seen in Operation.

**Webtron 650 5-color** **Listing #10061**  
1976, Width 6.5", 1/8 Gearing, 1 Product Rewind, 1 Waste Rewind, 3 Die stations, Sheeting station, Laminator, Edge guide, Auto Throw-off constant turn anilox, UV curing system, Stacker, Turn bar, and Can be seen in operation.

**Webtron 1000 5-color** **Listing #10619**  
1988, Width: 10", 1/8" Gearing, Automatic Throws / Constant Turn Anilox Rolls, 5 Dr. Blade Assemblies, 1 Product Rewind, 1 Waste Rewind, 2 Die Stations, 1 Sheeting Station, Underscoring Unit, 1 Hydraulic Edge Guide, 1 Stacker, 1 Spectra Cure Single-Lamp UV Unit, 8 Motorized Registration Units, 1 Strobe Light, Web Cleaning System, Approx. 5 Ceramic Anilox Rolls, 1990 Bunch Fan Folder, (1) set of Web 650 Die adapters.

**Webtron 650 6-color** **Listing #10606**  
1986, Width: 6.5", 1/8 Gearing, 6 Quick Change Anilox Assemblies, 6 Dr. Blade Assemblies, 6 Webtron 4-Way Heads, 6 Webtron OBS, 2 Product Rewinds, 1 Waste Rewind, 3 Die Stations, 1 Sheeting Station.

**Webtron 750 HQV 5-color** **Listing #10633**  
Width: 7.5", 1/8"-63T Gearing, 15" Print Repeat, Automatic Throws / Constant Turn Anilox Rolls, 5 Quick Change Anilox Assemblies, 5 Dr. Blade Assemblies, 5 Webtron 4-Way Heads, 5 Webtron OBS, 2 Product Rewinds, 2 Waste Rewinds, 30" Unwind Diameter, 3 Die Stations, 15.000" Die Repeat, 4 Removable Base Rolls, 1 Sheeting Station, 1 Laminator, 1 Edge Guide, 1 Turn-bar, Can see in Operation. Notes: Dover Steady Web Infeed Tension Control System.

**Webtron 750 5-color** **Listing #10605**  
1997, Width: 7.5", 1/8-63 Gearing, 4 Dr. Blade Assemblies, 4 Webtron 4-Way Heads, 4 Webtron OBS, 1 Product Rewind, 1 Waste Rewind, 30" Unwind Diameter, 3 Die Stations, 4 Removable Base Rolls, 1 Sheeting Station, 1 Hydraulic Edge Guide, Approx. 4 Ceramic Anilox Rolls, Hysteresis infeed tension system, (4) Dr. blade assy's, lower T-bar idler support system.

**Webtron 750 5-color** **Listing #10333**  
Width 7.5", 1/8 Gearing, Automatic Throws / Constant Turn Anilox Rolls, 5 Webtron 4-Way Heads, 1 Product Rewind, 30" Rewind Diameter, 1 Waste Rewind, 3 Die Stations, Sheeting Station, Laminator, 1 Air Edge Guide, Turn-bar, 1 Aetek Single-Lamp UV Unit, and Can be seen in Operation.

**Webtron 650 6-color** **Listing #10589**  
1983, Width: 6.5", 1/8 Gearing, 2 Dr. Blade Assemblies, Webtron OBS, 2 Product Rewinds, 1 Waste Rewind, 3 Die Stations, 1 Sheeting Station, 4 Way Bridges.

## PRESSES CONTINUED

- Webtron 650 6-color** Listing #10557  
1988, Width: 6.5", 32DP Gearing, Automatic Throws / Constant Turn Anilox Rolls, Dr. Blade Assembly, Webtron 4-Way Heads, Webtron OBS, 1 Product Rewind, 40" Rewind Diameter, 2 Waste Rewinds, 40" Unwind Diameter, 4 Die Stations, 4 Removable Base Rolls, 1 Laminator, 1 Edge Guide, 1 Single-Lamp UV Unit, Can see in Operation. RD Score Unit.
- Webtron 650 6-color** Listing #10292  
1979, Width: 6.5", 1/8 Gearing, 15" Print Repeat, Automatic Throws / Constant Turn Anilox Rolls, Webtron 4-Way Heads, Webtron OBS, 2 Product Rewinds, 30" Rewind Diameter, 2 Waste Rewinds, 30" Unwind Diameter, 4 Die Stations, 5 Removable Base Rolls, Sheeting Station, Laminator, Edge Guide, Stacker, and Can be in Operation.
- Webtron 1000 6-color** Listing #10459  
1987, 1/8 Gearing, 1 Waste Rewind, 1 Stacker, Approx. 215 Plate Cylinders, 40" OD Unwind Stand with integrated roll lift and magpower closed loop tension control, 6 print stations with 360 degree register controls (tandler gear boxes) & Quick impression rolls (one set undercut .015" overall to print up to 20 point board/second set O.D.) Dr Blades, and 2 Webtron 1125 die stations.
- Webtron 1000 6-color** Listing #10543  
Width: 10" 1/8 & 32DP Gearing, Automatic Throws / Constant Turn Anilox Rolls, 1 Product Rewind, 30" Rewind Diameter, 1 Waste Rewind, 40" Unwind Diameter, 2 Die Stations, 3 Removable Base Rolls, 1 Sheeting Station, 1 Edge Guide, 1 Turn-bar, 1 Stacker, 6 Motorized Registration Units, Can see in Operation. Mechanical Numbering Unit.
- Webtron 1000 6-color** Listing #10621  
1988, Width: 10", 1/8" Gearing, Automatic Throws / Constant Turn Anilox Rolls, Dr. Blade Assembly, 1 Product Rewind, 30" Rewind Diameter, 1 Waste Rewind, 30" Unwind Diameter, 2 Die Stations, 1 Sheeting Station, 1 Laminator, 1 Hydraulic Edge Guide, 1 Turn-bar, 1 Stacker, 1 Single-Lamp UV Unit, (9) 360 degree Registration Units, Approx. 10 Ceramic Anilox Rolls, Plate Cylinders, Can see in Operation. High Capacity Hot Air Drying System.
- Webtron 750 HQV 7-color** Listing #10632  
Width: 750", 1/8"-63T Gearing, 15" Print Repeat, Automatic Throws / Constant Turn Anilox Rolls, 7 Quick Change Anilox Assemblies, 7 Dr. Blade Assemblies, 7 Webtron 4-Way Heads, 7 Webtron OBS, 2 Product Rewinds, 2 Waste Rewinds, 30" Unwind Diameter, 3 Die Stations, 15,000" Die Repeat, 4 Removable Base Rolls, 1 Sheeting Station, 1 Laminator, 1 Edge Guide, 1 Turn-bar, 1 Aetek 400-WPI Single-Lamp UV Unit, Web Cleaning System, Cold Foil Stamping, Can see in Operation. Dover Steady Web Tension Control System. Does not include Video Web Inspection System.
- Webtron 8000 8-color** Listing #10544  
Width: 8", 1/8 & 32DP Gearing, 1 Product Rewind, 30" Rewind Diameter, 1 Waste Rewind, 1 Unwind, 40" Unwind Diameter, 3 Die Stations, 3 Removable Base Rolls, 1 Sheeting Station, 1 Hydraulic Edge Guide, 1 Turn-bar, 1 Stacker, Can see in Operation.
- Webtron 1000 8-color** Listing #10583  
Width: 10", 1/8" Gearing, 24" Print Repeat, Automatic Throws / Constant Turn Anilox Rolls, 1 Product Rewind, 40" Rewind Diameter, 1 Waste Rewind, 1 Unwind, 40" Unwind Diameter, 3 Die Stations, 24,000" Die Repeat, 4 Removable Base Rolls, 1 Sheeting Station, 1 Laminator, 1 Hydraulic Edge Guide, 1 Turn-bar, 1 Stacker, 1 Single-Lamp UV Unit, Motorized Registration Unit(s), 1 Video Web Inspection System, Approx. 14 Ceramic Anilox Rolls, Approx. 150 Plate Cylinders, Integrated Roll Lift on Unwind.
- Allied Gear 1-B 1-color** Listing #10603  
1990, Width: 7", 1/8" Gearing, 15" Print Repeat, Automatic Throws / Constant Turn Anilox Rolls, 2 Product Rewinds, 1 Waste Rewind, 1 Unwind, 3 Die Stations, 15,000" Die Repeat, 1 Electronic Edge Guide.
- Allied Gear 1B 3-color** Listing #10629  
1988, Width: 10", 1/8 Gearing, Automatic Throws / Constant Turn Anilox Rolls, 2 Product Rewinds, 1 Waste Rewind, 2 Die Stations, 1 Sheeting Station, 1 Electronic Edge Guide, 1 Stacker, Approx. 2 Ceramic Anilox Rolls, 1 Chrome Anilox Roll, Available September 2008.
- Allied Gear Flexomaster 1B 3-color** Listing #10305  
1987, Width: 7", 1/8 Gearing, 2 Product Rewinds, 1 Waste Rewind, 2 Die Stations, Sheeting Station, Edge Guide, Plate Cylinders, and Pre-determined counter.
- Allied Gear Flexomaster 1B 3-color** Listing #10407  
1988, Width: 7", 32 DP Gearing, 2 Product Rewinds, 1 Waste Rewind, 2 Die Stations, Sheeting Station, Laminator, Edge Guide, and a Stacker.
- Allied Gear 4-color** Listing #10241  
1986, Width: 10", 1/8 Gearing, 2 Product Rewinds, 1 Waste Rewind, 3 Die Stations, Sheeting Station, Stacker, Anilox Rolls, Web guide, 1" heavy duty walls, heavy duty dryer, new gears, new anvils, rebuilt print stations, new rollers & shafts, and Can be seen in Operation.
- Allied Gear 307 4-color** Listing #10199  
Approx. 1994, Width: 7", 1/8 Gearing, Automatic Throws / Constant Turn Anilox Rolls, Dr. Blade Assembly, 2 Product Rewinds, 2 Waste Rewinds, 4 Die Stations, 4 Removable Base Rolls, 1 Video Web Inspection System, Anilox Rolls, and Some spare parts.
- Allied Gear 516 6-color** Listing #10531  
1994, Width: 16", 1/8 Gearing, Automatic Throws / Constant Turn Anilox Rolls, 2 Product Rewinds, 40" Unwind Diameter, 1 Electronic Edge Guide, 1 Lighttouch 400-WPI Single-Lamp UV Unit, 1 Strobe Light, Approx. 12 Ceramic Anilox Rolls, Approx. 69 Plate Cylinders, Can see in Operation. Mechanical Crush knife slitter, manuals available.
- Aquaflex LX 1850 6-color** Listing #10497  
1999, Width: 18", mhours: 10220, 1/8 Gearing, 24" Print Repeat, Chill Rolls, Automatic Throws / Constant Turn Anilox Rolls, 6 Quick Change Anilox Assemblies, 6 Dr. Blade Assemblies, 2 Product Rewinds, 1 Unwind, 42" Unwind Diameter, 1 Sheeting Station, Electronic Edge Guide, 1 Aetek 400-WPI Single-Lamp UV Unit, (7) 360 degree



BR2200 "shockless" static neutralizing bar  
1 power supply operates two static bars  
115 or 230 VAC operation

## BR2200 STATIC CONTROL

Rectangle Static Bar w/ Power Supply

Toll Free: + 1 800 678 7222 ■ Telephone: + 1 847 818 1100

## Opti-Web Infeed Tension System

For Webtron 650 or 750

### Tension Control~

This outstanding new retrofit is designed and proven to maintain an extremely accurate tension zone on your Webtron 650 or 750 Press. The Opti-Web System is oscillation free due to the isolation drive that eliminates rough braking conditions which cause web tension disruptions and misregistration.



Toll Free: + 1 800 678 7222 ■ Telephone: + 1 847 818 1100 ■ Fax: + 1 800 678 7983 ■ Email: [info@aaapress.com](mailto:info@aaapress.com)

## PRESSES CONTINUED

### Stacker

For Webtron 650/750



#### FEATURES:

Custom made for your gearing ■ Roller deck assembly ■ Pressure arm ■ Back-up plate ■ Static Neutralizer ■ Upper & Lower stacker pins ■ Powered by the press ■ Durable with long life expectancy

Toll Free: + 1 800 678 7222 ■ Telephone: + 1 847 818 1100

Registration Units, Approx. 6 Ceramic Anilox Rolls. Hydraulic Roll Lift, Magpower closed loop tension control system with electro magnetic brake, Single Side Corona treating unit for non-conductive material) with frame, closed loop variable infeed tension control, Five (5) drying units including infra-red lamps and hot air blowing with suction, One (1) combo IR and UV, 6) enclosed doctor blades assemblies (printing width is reduced by 1/4"), Slitting station with 3 air knives and lateral adjustment, Outfeed air nip roll station, One (1) Sheeting and Cross Perforation Station for top cutting, Unwind Lamination with 24" OD soft tension (magnetic brake control), Chill roll module for U.V. lamination with 16" (406 mm) chill roll and frame with UV curing mounting bracket (without chiller and dryer), Motorized dual rewind with automatic tension control upgrade, Pressman Walkaways, Predetermined Electronic Counter, Drying package for non-absorbent material including high capacity dryers with blast gates, manifold duct from blowers to the press, variable infra-red lamps with potentiometer on each unit and chromed impression rolls for six (6) print units, Closed loop temperature control (hot air), In Very Good Condition!

**Aquaflex DBXF 803 7-color Listing #10326**  
1995, Width: 8", 1/8 Gearing, 18" Print Repeat, Anilox Rolls, Approx 25 Anilox Rolls, IR with 1 UV Unit, and Can be seen in Operation.

**Aquaflex Prestige 9-color Listing #10513**  
2001, Width: 20.5", 1/8 Gearing, 24" Print Repeat, 2 Stork Rotary Screen Units, 7 Chill Rolls, Automatic Throws / Constant Turn Anilox Rolls, 9 Quick Change Anilox Assemblies, 9 Dr. Blade Assemblies, 1 Product Rewind, 30" Rewind Diameter, 1 Waste Rewind, 1 Die Station, 2 Laminators, 2 Electronic Edge Guides, 8 Single-Lamp UV Units, 7 Motorized Registration Units, Hot Foil Stamping, Anilox Rolls, Plate Cylinders, Can see in Operation. Runs 1/2 mil Poly upto standard PS label stock! Includes corona treater, motorized infeed and exit stations, 2 Web Guides, 14 Extra Print Cassettes, Crane System. Does NOT include Unwind Stand. Over \$1.5 Million New!

**Aquaflex Instaflex 9-color Listing #10405**  
1998, Width: 16.5", 1/8 Gearing, 9 Dr. Blade Assemblies, 1 Product Rewind, 1 Waste Rewind, 2 Sheeting Stations, Turn-bar, 9 VTI 600 WATT Single-Lamp UV Units, 2 Strobe Lights, Hot Foil Stamping, and Approx. 27 Ceramic Anilox Rolls.

**Aquaflex XL3 208 9-color Listing #10406**  
Width: 32", 1/8 Gearing, 24" Print Repeat, 14 Dr. Blade Assemblies, 42" Rewind Diameter, 1 Waste Rewind, 42" Unwind Diameter, 1 Die Station, (8) 360 degree Registration Units, Approx. 24 Ceramic Anilox Rolls, Approx. 66 Plate Cylinders, Hydraulic Roll lift, Electronic web guide, Variable infeed dual air nip station, (17) in line chill rolls for extensible film printing, (4) Reverse print decks for backside printing (1,2,7,8), (1) NXGA-5 Closed loop water chiller,(9) High Capacity IR Dryers, Extended IR drying tunnel for Aquious Coatings, (9) Peristaltic Ink Pumps, (2) Aetek 400 WPI UV Curing Units (Portable between stations 7,8 or 9), (1) Soft- tension Laminator with closed Copd Tension control, two sided video web inspection system with auto Traverse, (110) 1/8 Geared Plate cylinders,Max Printing width 31.5", (1) Pneumatic Crush knife

slitting unit, (1) shear knife slitting unit, (1) Bowed roller for web separation after slitting, Die cutting unit, sheeting conveyor, (1) rewind unit, 42" O.D. Capacity, including 3" & 6" Coreshafts, and closed loop tension control,(2) Electronic totalizing counters, and walkway including between decks.

**Aquaflex DBX-1000 12-color Listing #10572**  
1992, Width: 10", 1/8" Gearing, 24" Print Repeat, Automatic Throws / Constant Turn Anilox Rolls, 1 Product Rewind, 36" Rewind Diameter, 2 Waste Rewinds, 1 Unwind, 40" Unwind Diameter, 3 Die Stations, 24.000" Die Repeat, 4 Removable Base Rolls, 1 Sheeting Station, 2 Laminators, 3 Electronic Edge Guides, 2 Single-Lamp UV Units.

**Comco Commander 4-color Listing #10429**  
1990, Width: 16", 2 Product Rewinds, 1 Waste Rewind, 4 Die Stations, and a Laminator.

**Comco Commander 5-color Listing #10581**  
1993, Width: 10", 1/8 Gearing, Automatic Throws / Constant Turn Anilox Rolls, Dr. Blade Assembly, 2 Product Rewinds, 24" Rewind Diameter, 1 Waste Rewind, 30" Unwind Diameter, 3 Die Stations, 1 Sheeting Station, 1 Edge Guide, 1 Turn-bar, 1 Stacker, 7 UV Technology Single-Lamp UV Units, Anilox Rolls, Can see in Operation. Manuals available, Ink Pumps, Option of Comco or Allied Tooling.

**Comco Commander 9-color Listing #10600**  
1992, Width: 18", 1/8" Gearing, 24" Print Repeat, Automatic Throws / Constant Turn Anilox Rolls, Quick Change Anilox, 1 Product Rewind, 30" Rewind Diameter, 2 Waste Rewinds, 1 Unwind, 40" Unwind Diameter, 3 Die Stations, 24.000" Die Repeat, 3 Removable Base Rolls, 1 Sheeting Station, 1 Laminator, 1 Hydraulic Edge Guide, 1 UV Research 400-WPI Single-Lamp UV Unit, 12 Motorized Registration Units, 1 Video Web Inspection System, Approx. 14 Ceramic Anilox Rolls, Can see in Operation. Integrated unwind roll lift, Steady web web tension control, Enercon 16" single sided corona treater. Press runs polypropylene laminate, PVC shrink film, 60 LB litho paper, 25 lb craft paper and PS label stock.

**Didde-Glaser 4-color Listing #10453**  
Width: 17", 14" Print Repeat, 1 Turn-bar, (4) Blank Cabinets with drive shaft, Quad Flow dampening, (1) IR drier, and was refurbished in 2004.

**Edale 3-color Listing #10387**  
1985, Width: 7", 1/8 Gearing, 16" Print Repeat, Automatic Throws / Constant Turn Anilox Rolls, 2 Product Rewinds, 24" Rewind Diameter, 2 Waste Rewinds, 22" Unwind Diameter, 3 Die Stations, 3 Removable Base Rolls, Sheeting Station, Laminator, Stacker, Manuals included, Spare parts included, 150 4" Rotary dies included, and Can be seen in Operation.

**Fab Print Roll Fed Screen Printer Listing #10097**  
1989, Width: 27", Two print stations, Max print image area 24" x 20", Aprx. 30 screen frames, Unwind stand with loop box, Horizontal dryer, Tower dryer, and Heavy duty rewind with loop box.

**Gallus R 160B - Rotary Silk Screen Press 4-color Listing #10208**  
1984, Width: 7", 1/8 Gearing, 18" Print Repeat, 1 Product Rewind, 20" Rewind Diameter, 2 Waste Rewinds, 30" Unwind Diameter, 2 Die Stations, Sheeting Station, Laminator, Edge Guide, Turn-bar, Stacker, 7.5 Ton chiller sys for chilled rollers & lights, flat bed emboss/die cut unit, includes roto screen making and mounting equipment, misc gears & ring sets, ink pumps, UV unit, and Can be seen in Operation.

**Gallus R 160 4-color Listing #10157**  
1993, Width: 7", 1/8 Gearing, 1 Product Rewind, 1 Waste Rewind, 2 Die Stations, Edge Guide, 4 Gallus Single-Lamp UV Units, Corotec treater, chiller, set up for silk screen.

**Gallus R-200B02 8-color Listing #10636**  
1990, Width: 8", 4 Gallus Rotary Screen Units, Chill Rolls, 1 Product Rewind, 1 Waste Rewind, 2 Die Stations, 1 Edge Guide, 1 Stacker, 7 UV Technology 400-WPI Single-Lamp UV Units, Auto Registration Unit(s), 1 Video Web Inspection System, Hot Foil Stamping, Approx. 2 Ceramic Anilox Rolls, Plate Cylinders, 7 RLP Stations, 1 Flexo Station, 4 Interchangeable Rotary Screen Heads with Screen Cut and Mount System, 40 Scree Ring/Gear Sets, Flat-Bed Dicutter with 32 Dies, Enercon XL Series Corona Treater, Hot Stamp with Unwind, Rewind and 40 Dies; Trim Removal System, Heated Plate for Stripping Assist, Chiller, Delam/Relam Kit, (42) RLP Pate Cylinders, (10) Flexo Plate Cylinders, (5) Stepped Base Rolls, 12" x 15" Water Wash Plate Maker.

**Kammann K61a Flat Screen Press 6-color Listing #10493**  
1985, Width: 12.5", 14" Print Repeat, 40" Rewind Diameter, 1 Waste Rewind, 1 Unwind, 40" Unwind Diameter, Auto Registration Unit(s), Web Cleaning System, Hot Foil Stamping, 1 Flexo Print Station (reversible) with UV/IR Drying, 5 Flat Screen Print Stations with IR/UV drying/electronic registration on each unit, Hot foil Stamping After Screen Unit 4, Sprocket Punching after Screen Unit 5, Flat Bed Die Cutting After Screen Unit 5, Rotary Horizontal Perforating after unit 5, Salvage waste removal after unit 5.

**Ko-Pack 170 Rotary Letterpress 5-color Listing #10024**  
1979, Width: 7", 32 DP Gearing, 18" repeat, 3 Rotary dies , 22" Unwind diameter, UV on all stations, In-line slitting, Plate cylinders, assorted gears and bearings, Spare C.I. drum, and Can be seen in operation.

**Manhasset 4-color Listing #10455**  
1969, Width: 7", 32 DP Gearing, 2 Product Rewinds, 30" Rewind Diameter, 1 Waste Rewind, 32" Unwind Diameter, 2 Die Stations, 1 Sheeting Station, 1 Stacker, 4 color on a 5

## PRESSES CONTINUED

color frame, Conveyor stacker, Hydraulic web guide, chrome anilox rolls, and spare parts!  
**Manhasset 609 MAP-L 5-color** Listing #10380  
 1978, Width: 9", 1/8 Gearing, 2 Product Rewinds, 1 Waste Rewind, 3 Die Stations, Stacker, 7 H.P motor, All Plate roll shafts, Electronic web guide, Can print both sides of material, and Appox from Mid-1970.

**Nilpeter F-280 6-color** Listing #10615  
 1992, Width: 11", 1/8" Gearing, Automatic Throws / Constant Turn Anilox Rolls, 6 Dr. Blade Assemblies, 1 Product Rewind, 30" Rewind Diameter, 1 Waste Rewind, 1 Unwind, 3 Die Stations, 3 Removable Base Rolls, 1 Sheeting Station, 1 Laminator, 1 Electronic Edge Guide, 1 Turn-bar, 1 Stacker, 1 300-WPI Double-Lamp UV Unit, 9 Automatic Registration Units, Approx. 20 Ceramic Anilox Rolls, Approx. 60 Plate Cylinders, Can see in Operation. Comco unwind stand, shear cut slitting, RD scorer unit.

**Propheteer 700 4-color** Listing #10477  
 1982, Width: 7", 1 Product Rewind, 2 Waste Rewinds, 3 Die Stations.

**Propheteer 1000 5-color** Listing #10630  
 1990, Width: 10", 1/8" Gearing, Automatic Throws / Constant Turn Anilox Rolls, 2 Product Rewinds, 2 Waste Rewinds, 3 Die Stations, 3 Removable Base Rolls, 1 Laminator, 1 Electronic Edge Guide, 1 Turn-bar, 1 Brewer Cool UV 400-WPI Single-Lamp UV Unit, M/F Rotary Punch Unit, Approx. 14 Ceramic Anilox Rolls, Approx. 86 Plate Cylinders, Can see in Operation. Bunch 590 Fanfolder. Delphax EBI 150W Ion Deposition Unit sold separately.

**Propheteer 700 6-color** Listing #10467  
 1987, Width: 7", 1/8 Gearing, 2 Product Rewinds, 1 Waste Rewind, 3 Die Stations, 1 Sheeting Station, Edge Guide, 1 Turn-bar, Can see in Operation. Video web inspection with strobe lamp, rotmetric plate cylinder, Rotary dies, Air Slitters, 2 -Brewer-1989 UV single lamp uv curing systems including towers.

**Propheteer 1000 6-color** Listing #10613  
 1997, Width: 10", 1/8 Gearing, Automatic Throws / Constant Turn Anilox Rolls, 2 Product Rewinds, 30" Rewind Diameter, 2 Waste Rewinds, 1 Unwind, 40" Unwind Diameter, 3 Die Stations, 24.000" Die Repeat, 4 Removable Base Rolls, 1 Sheeting Station, 1 Electronic Edge Guide, 1 Lightouch 300-WPI Double-Lamp UV Unit, 5 Motorized Registration Units, Can see in Operation. Closed-loop infeed pacing system, RD Scorer Unit.

**Propheteer 1700 8-color** Listing #10541  
 1991, Width: 18" 1/8 Gearing, Automatic Throws / Constant Turn Anilox Rolls, 1 Product Rewind, 60" Rewind Diameter, 2 Waste Rewinds, 60" Unwind Diameter, 4 Die Stations, 2 Removable Base Rolls, 1 Sheeting Station, 1 Edge Guide, 1 Turn-bar, 1 Stacker, 1 Single-Lamp UV Unit, Ink Pumps, Manuals available, DMS Rotary Hot Stamp, 1 Reverse Print Station, Laminating Tower with Waste Rewind, about 40 Anilox Rolls & 280 Print Cylinders, 1 Roll Runner III.

**Scribe 5-color** Listing #10474  
 1980, Width: 8.5", 1/8 Gearing, 20" Print Repeat, 1 Product Rewind, 30" Rewind Diameter, 3 Waste Rewinds, 30" Unwind Diameter, 4 Die Stations, Can see in Operation. Sheeter, Stacker, Laminator, Laminator Liner Rewind, Edge Guide, Turn Bar, UV Curing System, Manuals available.

**Shiki MFG PC45 ML 3-color** Listing #10383  
 1979, Width: 10", 5" Print Repeat, 1 Product Rewind, 1 Waste Rewind, 2 Die Stations, Laminator, Laminator liner rewind, U.V Curing system (Optional), auto registration, and variable speed matrix rewind.

**Shiki MFG Co. PC45 ML 3-color** Listing #10384  
 1984, Width: 10", 5" Print Repeat, 1 Product Rewind, 1 Waste Rewind, 2 Die Stations, UV Curing system optional, lengthened press for UV curing, and variable speed matrix rewind.

**Shiki F-330 Web Offset Press 6-color** Listing #10638  
 1990, Width: 13", 28" Rewind Diameter, 30" Unwind Diameter, 6 Ushio 400-WPI Single-Lamp UV Units, Approx. 12 Plate Cylinders. 12 Plate Cylinders and 12 Blanket Cylinders. Manuals available. Electrical requirements: 230 volts, 3 phase. Can see in Operation.

## SLITTERS, REWINDERS &amp; DIECUTTERS

**Allen Data Graph DF-1600/IT-1600 Slitter / Rewinder** Listing #20217  
 Width: 16", 1 Die Station, 1 Product Unwind, 3" Unwind Core Diameter, 1 Product Rewind, 3" Rewind Core Diameter, 2 Waste Rewinds, 1 Laminating Unwind, 10 Maximum Speed, Can see in Operation. Digital Servo, microprocessor controlled, full HPGL vector cutting with Smartmark re-register opto-electric line sensor & carbide tip cutting blade. Excellent Condition!

## Sprayway

High-performance aerosols.



Flexo Spraykote ■ Silicone Spray ■ Teflon Dry Lube ■ Rubber Roller Cleaner ■ Film Cleaner ■ Spray Adhesive ■ Dust Remover ■ Spot Lifter ■ Adhesive Remover ■ Orange Power Cleaner ■ Anti-skin No wash

Toll Free: + 1 800 678 7222 ■ Telephone: + 1 847 818 1100

## Check-out our monthly email Newsletter?

We deliver information on hot new industrial products, equipment, press room accessories, supplies, service, and more.



... log on to [www.aapress.com/e-newsletter.html](http://www.aapress.com/e-newsletter.html) & subscribe TODAY!

## SLITTERS, REWINDERS & DIECUTTERS CONTINUED

### REVolutionary

Praxair's REVolutionary Ceramic Anilox Engraving Technology provides outstanding ink density while printing critical process, text, or screen work with a **single engraved cylinder**. Reduce Anilox Inventory with all purpose REV Technology.



Distributed by AAA Press International, Inc.

Toll Free: +1 800 678 7222 ■ Telephone: +1 847 818 1100

- Arpeco Slitter / Rewinder** Listing #20207  
2001, Width: 13", Electric Edge Guide, Underscoring Unit, 1 Die Station, 3" Unwind Core Diameter, 30" Unwind Diameter, 1 Product Rewind, 3" Rewind Core Diameter, Unilux Inc Strobe Light, Individual Label Counter, Dual Speed Rewind, Web Advance, Can see in Operation. Max Speed 750 FPM.
- Arpeco Tracker Premier / Slitter / Rewinder** Listing #20222  
1999, Width: 13", Electric Edge Guide, Shear Cut Slitting, 1 Product Unwind, 3" Unwind Core Diameter, 30" Unwind Diameter, 1 Product Rewind, 3" Rewind Core Diameter, 18" Rewind Diameter, Strobe Light, 10" Incremental Length Counter, Individual Label Counter, Missing Label Detector, Flag Detector, Splice Detector, 935 Maximum Speed, Labels In / Labels Out, Quad Torch Rewind, Web Advance, Can see in Operation. 230VAC/3Ph/30A.
- Arpeco Tracker Premier / Slitter / Rewinder** Listing #20223  
2000, Width: 13", Electric Edge Guide, Shear Cut Slitting, 1 Product Unwind, 3" Unwind Core Diameter, 30" Unwind Diameter, 1 Product Rewind, 3" Rewind Core Diameter, 18" Rewind Diameter, Strobe Light, 10" Incremental Length Counter, Individual Label Counter, Missing Label Detector, Flag Detector, Splice Detector, 935 Maximum Speed, Labels In / Labels Out, Quad Torch Rewind, Web Advance, Can see in Operation. 230VAC/3Ph/30A.
- Arpeco Tracker Slitter / Rewinder** Listing #20220  
1982, Width: 16", Hydraulic Edge Guide, Shear Cut Slitting, 1 Product Unwind, 3" Unwind Core Diameter, 28" Unwind Diameter, 1 Product Rewind, 3" Rewind Core Diameter, 16" Rewind Diameter, 16" Rewind Diameter, 10" Incremental Length Counter, 500 Maximum Speed, Web Advance.
- Arpeco Tracker Slitter / Rewinder** Listing #20215  
1987, Width: 13", Hydraulic Edge Guide, Shear Cut Slitting, 3" Unwind Core Diameter, 28" Unwind Diameter, 1 Product Rewind, 3" Rewind Core Diameter, 16" Rewind Diameter, Strobe Light, 10" Incremental Length Counter, 500 Maximum Speed, Dual Speed Rewind, Labels In / Labels Out, Web Advance.
- Arpeco Tracker Slitter / Rewinder** Listing #20177  
1997, Width: 13", Hydraulic Edge Guide, Shear Cut Slitting, 29" Unwind Diameter, 8" Rewind Diameter, 10" Incremental Length Counter, Individual Label Counter, 500 Maximum Speed, 1.25" core holder, Integrated Roll lifter.
- Arsoma IMC TR 450 Turret** Listing #20219  
1989, Width: 17", 3" Rewind Core Diameter, 5 Turret Rewind Spindles, Hot Melt Core Glueing, Auto Core Eject, Air Coreholders, Encoder assembly for press speed reference.

- Aztech Siewinder II Slitter/Rewinder** Listing #20205  
1997, Width: 10", Electric Edge Guide, Shear Cut Slitting, 3" Unwind Core Diameter, 24" Unwind Diameter, 2 Product Rewinds, 3" Rewind Core Diameter, 18" Rewind Diameter, Individual Label Counter.
- CTC Matrix Butt Splicer** Listing #20153  
1998, Width: 16".
- CTC S-RMAB-36-10 Roll Master / Butt Splicer** Listing #20190  
2005
- CTC S-RMAB-42-13 Butt Splicer** Listing #20150  
1996, Width: 13", 220 Volt, 80 PSI, 500 Feet per Minute, Festoon cabinet for dancing rolls, and 42" Max OD.
- CTC S-RMAB-42-20 Butt Splicer** Listing #20151  
1996, Width: 20", 220 Volt, 80 PSI, 500 Feet per minute, Festoon cabinet for dancing rolls, and 42" Max OD.
- CTC Turret Rewinder ST200-13-20 Slitter / Rewinder** Listing #20229  
1992, Width: 13", 3 Product Rewinds, 3" Rewind Core Diameter, 20" Rewind Diameter, 3 Turret Rewind Spindles, Air Coreholders, 220VAC/3Ph, Tach Generator not included.
- Kluge EHD Die Cutter** Listing #20006  
1998, 13" x 19", Hot Stamping capability, Less than 2000 meter hours, Excellent condition, and Can see in operation.
- Omega 3300 Slitter / Rewinder** Listing #20226  
1998, Width: 13", Electric Edge Guide, Shear Cut Slitting, 1 Product Unwind, 3" Unwind Core Diameter, 1 Product Rewind, 3" Rewind Core Diameter, Unilux Strobe Light, Individual Label Counter, Dual Speed Rewind, Additional 1" OD rewind Coreholder. Can see in Operation.
- Propheteer R10 Slitter/Rewinder** Listing #20144  
Width: 10", Crush Cut Slitting, 28" Unwind Diameter, 16" Rewind Diameter, and Electronic counter.
- PIC Slitter/Rewinder** Listing #20154  
1996, Width: 16", Razor Knife Slitting, 1 Product Rewind. S&E Roll Lift, Splicing Clamps, Touch Screen needs reprogramming, and Manuals are included.
- PMC Diecutter Slitter/Rewinder** Listing #20191  
Width: 6.25", 1 Die Station, Bottom Up flat die cutter. Max diecut 6.25" x 6.25", Min diecut 1.125" x 1.125". 1/32" die tolerance. Many flat dies included.
- Rotoflex DLI 330 Vericut Config 1 / Diecutter** Listing #20224  
2007, Width: 13", Electric Edge Guide, Shear Cut Slitting, Underscoring Unit, 2 Die Stations, 19" Die Station Repeat, 3" Unwind Core Diameter, 28" Unwind Diameter, 1 Product Rewind, 3" Rewind Core Diameter, 20" Rewind Diameter, 1 Waste Rewind, 28" Waste Rewind Diameter, 1 Laminating Unwind, Individual Label Counter, 300 Maximum Speed, 2 Servo Die Stations - includes one mag die cylinder. One Flood Coating Station with UV / IR Dryer. One Conveyor Stacker. Maximum speed 300 coating and 140 die cutting. Purchased new in 2007 for \$220,000.00.
- Rotoflex DLI-500 Diecutter** Listing #20185  
2003, Width: 20", Electric Edge Guide, Shear Cut Slitting, Underscoring Unit, 3 Die Stations, 3 Removable Base Rolls, 3" Unwind Core Diameter, 40" Unwind Diameter, 1 Product Rewind, 3" Rewind Core Diameter, 26" Rewind Diameter, 2 Waste Rewinds, Strobe Light, Individual Label Counter, 750 Maximum Speed, Web Advance, Can see in Operation.
- Rotoflex HTI-250 Slitter / Rewinder** Listing #20195  
2002, Width: 10", Dual Camera Inspection System, Multiple Splicing Tables, Web Guide, Bi-directional Pharmaceutical Label Inspection.
- Rotoflex Vericut Config 1 DLI-330 Diecutter** Listing #20216  
2005, Width: 13", Electric Edge Guide, Shear Cut Slitting, Underscoring Unit, 1 Die Station, 17" Die Station Repeat, 1 Product Unwind, 3" Unwind Core Diameter, 28" Unwind Diameter, 1 Product Rewind, 3" Rewind Core Diameter, 20" Rewind Diameter, 1 Waste Rewind, 27" Waste Rewind Diameter, 1 Laminating Unwind, 10" Incremental Length Counter, Individual Label Counter, 165 Maximum Speed, Servo Driven Unwind, Rewind and Diecutting. Automatic register and re-register with continuous correction. (1)Flood Coating Station with ceramic anilox, rubber tint roll, enclosed dr blade system and sunday drive. (1)Combination Lighttouch 400 WPI UV with Maximizer IR dryer for UV Varnish and water based primer drying.
- Rotoflex VIR 600 / Rewinder** Listing #20118  
1998, Width: 24", Electric Edge Guide, 40" Unwind Diameter, 40" Rewind Diameter, Strobe Light, Individual Label Counter, 1000 Maximum Speed, Automatic stop on roll end, Adjustable web guide sensor, 1-6" Rewind and Unwind shaft, Vertical inspection area, and in Excellent Condition!
- Rotoflex VLI 400 Slitter / Rewinder** Listing #20214  
1991, Width: 16", Electric Edge Guide, Crush Cut Slitting, 3" Unwind Core Diameter, 40" Unwind Diameter, 1 Product Rewind, 3" Rewind Core Diameter, 10" Incremental Length Counter, Web Advance, 4 crush cut knives, foot pedal jog.
- Stanford Doctor Machine Model 142 XLT** Listing #20031  
Approx 1993, Width: 30", Light gauge extensible film rew, 24" Unwind/Rewind dia, 3 Hp

**SLITTERS, REWINDERS & DIECUTTERS CON.**

driven unwind motor & control, 5 Hp eddy current drive complete w/transistorized control panel & operator control station, 1000 fpm, Automatic web guide, Razor trimming, Auto tension control, and Air operated rider roll.

**FILM & PLATE**

- Anderson Vreeland Orbital X / Orbital Plate Maker** Listing #30081  
2006, Length: 12", Width: 18", Flexo, Exposure, Water Washout, Dryer, 3 Drying Drawers, Detach, Mint...Like New Condition.
- Anderson and Vreeland Plate Maker** Listing #30062  
1992, Length: 20", Width: 30".
- Anderson Vreeland Rotary Plate Washout** Listing #30070  
Length: 30", Width: 44", Flexo, Solvent Safe Washout, 230 VAC 15amps.
- Anderson Vreeland Washout Unit** Listing #30005  
1998 model, Length: 18", Width: 30", and Rotary washout unit.
- Agfa Selectset 5000 Imagesetter with RIP** Listing #50309  
Agfa Imagsetter includes Harlequin Xitron 5.xxx software RIP on an Windows NT Server (no monitor).
- Beseler 191MD / "L" Sealer with Heat Shrink Tunnel** Listing #50310  
Width: 14", Length: 8", Can see in Operation.
- Crosfield Electronics Celix 4000 Film Processor** Listing #30078  
1996, Length: 40", Width: 0", Flexo.
- Dupont 1000 Exposure Unit** Listing #30053  
2002, Length: 47", Width: 35", Flexo, Letterpress, Exposure, Solvent Washout, Detach, Can be seen in Operation, Chilled exposure bed to keep plate cool, New exposure bulbs in 06/06, Extra ballast included, 3 Drawers for plate/film storage, PM done by Dupont in 11/05, and no Plate dryer included!
- Dupont Cyrel Exposure Unit FX4036** Listing #30007  
Length 30", Width: 40". Available immediately!
- Dupont Cyrel M-5096 - 3248 LT FIN-PX Plate Maker** Listing #30076  
1988, Length: 32", Width: 48", Flexo, Finishing and post exposure unit with cycle timers.
- Encore Engineering - MX-138 / Squeegee Sharpener** Listing #50311  
2002, Width: 24".
- Kelleigh 220 Plate Maker** Listing #30071  
Width: 0", Solvent System, Inline Processor and Dryer, 220v-3ph-15amp

**FILM & PLATE CONTINUED**

- Kelleigh 233 Rotary Plate Maker** Listing #30067  
1990, Length: 15", Width: 12", Flexo, Exposure, Solvent Washout, Dryer, 3 Drying Drawers, Detach, Can see in Operation.
- Kelleigh 237 Light Finisher** Listing #30023  
Length: 24", Width: 30", Flexo, Includes automatic timers.
- Kelleigh 240 Plate Maker** Listing #30050  
Length: 24", Width: 30", and four Drying Drawers.
- Kelleigh 249 Post Exposure / Plate Detack** Listing #30066  
1994, Length: 32", Width: 48", Flexo, Detach, Flexo Post Exposure and Plate Detack Unit.
- Kelleigh 266 Orbital Fast-line plate making system** Listing #30064  
2000, Length: 24", Width: 30", Flexo, Solvent Washout, Dryer, 5 Drying Drawers, In-line Automatic plate system. Additional 6 drawer dryer included.
- Kelleigh 270 In-line Plate Processor** Listing #30030  
1998, Length: 24", Width: 30", Flexo, Solvent Washout, 5 Drying Drawers, 1 Orbital brush for washout, 2 rotary brushes for clean up. Very good concondition.
- Kelleigh 310 Rotary Plate Maker** Listing #30080  
Length: 24", Width: 30", Flexo, Exposure, Solvent Washout, Dryer, 3 Drying Drawers.
- Kelleigh 3248 Orbital** Listing #30075  
1998, Width: 32", 48" x 32", Solvent Washout, Dryer, 4 Drying Drawers.
- Olec OV45HD / Exposure Unit** Listing #30069  
Length: 45", Width: 0", Flexo, Exposure, Automatic Light diffuser option for optimal plate exposure. 220 VAC 50amps. Combine with 30068 & 30070 for complete high capacity plate making system.
- Progressive Recovery PV-20 Solvent Recovery System** Listing #30077  
1993, Width: 0", Flexo, Plate Vac - 20 Gallon Solvent Recovery capacity.
- Starflex 860 Rotary Plate Maker** Listing #30032  
1989, Length: 18", Width: 24", Exposure, Solvent Washout, 3 Drying Drawers, Light finisher, includes 1 extra new set of washout brushes, separate vacuum pump, box misc parts, and manuals are included!
- Toray Plate Maker Model TTP460** Listing #30014  
Length: 18", Width: 24", Rebuilt in 2002, Water washout, Inline w/brush type washout and dryer.

**SHIMPO**

Strobe Lights DT-311

**Features:**

- Extruded aluminum construction
- Highly accurate (+/- 0.01 of reading)
- Phase shift
- High flash rate (up to 35,000 FPM)
- Microprocessor-controlled
- External trigger
- Synchronous output
- Flash timer control
- Continuous duty cycle

Toll Free: + 1 800 678 7222 ■ Telephone: + 1 847 818 1100

**Unilux Lith-O-Light 5**

Inspection Strobe Light

**Features:**

- 9" wide full web inspection
- Excellent brightness illuminates sharp details
- Flexible - handheld or articulated mounting with rechargeable battery or A/C adaptor

Find out more about Unilux strobe light, visit our web site at:

[www.aaapress.com/strobe-light.html](http://www.aaapress.com/strobe-light.html)

## MISC. EQUIPMENT CONTINUED

<b>Agfa Selectset 5000 / Processor</b> In Good working condition!	<b>Listing #50125</b>	<b>Mark Andy Plate Cylinders</b> Width: 7", Approx. 97 plate cylinders, list available.	<b>Listing #50188</b>
<b>Allied Gear BS078 Bottom Stacker</b> Width: 7". For a FlexoMaster 1B.	<b>Listing #50164</b>	<b>Mark Andy Print Cylinders (73)</b> 125 pitch.	<b>Listing #50242</b>
<b>Appleton BIMS 2 Core Cutter</b> 1973, Length: 90", Heavy Duty Core Cutter.	<b>Listing #50306</b>	<b>Mark Andy T &amp; P Unit &amp; PerfUnit Combo</b>	<b>Listing #50223</b>
<b>Appleton Model D Core Cutter</b> Length: 60"	<b>Listing #50300</b>	<b>Markem Hot Stamp Unit LP-275</b>	<b>Listing #50151</b>
<b>B. Bunch 590 Fan Folder</b>	<b>Listing #50301</b>	1978, Length: 4", Width: 4", 1 Product Rewind, 2 foil unwinds, and manuals are available.	
1992, Width: 10", unning register controls, motorized delivery table, batch counter, 50+ fold length change gears.		<b>Markem Hot Stamp Unit LP-375</b>	<b>Listing #50150</b>
<b>B. Bunch 600 Fan Folder</b>	<b>Listing #50303</b>	1981, Length: 4", Width: 4", 1 Product Rewind, 1 Waste Rewind, 2 foil unwinds, and guillotine cutter.	
1982, Width: 20", Length: 14", Running register controls, batch counter with motorized delivery table, 11 fold length change gears.		<b>MicroClean 48A / Anilox Cleaning System</b>	<b>Listing #50313</b>
<b>Bieffebi Mounter Proofer Model Mirage 70</b>	<b>Listing #50028</b>	2003, Minimum roll length is 6" and 1" diameter and the maximum length is 37" and 5" diameter. Power requirements: 60 Hz - 110 volts, 14 amps, and 60 PSI. Copy of manual available. Can view equipment, however it is not currently under power. Equipment is in good working order.	
1985, Width: 27.5", Repeat range 3" - 29 1/2", Refurbished in 1996, and in Excellent condition!		<b>MicroClean (2) Anilox Cleaner</b>	<b>Listing #50270</b>
<b>Bio Blast Accustrip 11SX</b>	<b>Listing #50175</b>	2001 & 2003 Units, 37" Max rolls, 6" Min Rolls.	
Baking Soda Anilox Cleaner, 1998, Width 20", Dry Application, good condition, Cleaning Cabinet Model 3600 single roll, Vacuum Recovery Unit Model 3600BVR single filter, and a max capacity 20" wide anilox.		<b>Nilpeter FA-3300 New Praxair Ceramic Anilox Roll</b>	<b>Listing #50263</b>
<b>Bio Blast Baking Soda Anilox Cleaner</b>	<b>Listing #50011</b>	Width: 13", 400 LPI 5.2BCM.	
2000, Model 2400. Complete system, Very good condition, Approximately 20 hours, and Will handle 20" rolls!		<b>Pillar Techn. P6000 / Single Side Corona Treater</b>	<b>Listing #50287</b>
<b>Champion Compressor HR10D25 / Duplex 10.HP</b>	<b>Listing #50197</b>	2007, Width: 19". Never used, never installed, Integrated Power Supply, Single Sided Treatment Barrow Web, Blower, Blower Motor Starter, Proportional Speed Contro.	
1995, Delivers approx. 43 CFM per each pump, 250 gallon receiver tank, Two stage high pressure pump to 175 p.s.i. Integrated after-cooler for each pump head, 230 volt 3 phase, and Operating Manual included. In Very good condition!		<b>Plate Mounter</b>	<b>Listing #50029</b>
<b>Corotec UFWRB 104-C / Bare Roll Corona Treating</b>	<b>Listing #50308</b>	1996 TP200, Width: 13"..	
2004, Width: 10", Includes exhaust blower (230VAC/3Ph/8A), power supply (110VAC)and treater station. Less than 1 year of use!		<b>Praxair Ceramic Anilox Rolls (42)</b>	<b>Listing #50153</b>
<b>Devotec Film Processor</b>	<b>Listing #50054</b>	13" & 16" anilox rolls 450,600,700 & 800 line used on a Comco Proglide press.	
1993; Can be seen in Operation.		<b>Propheteer Print Cylinders Listing #50004</b>	
<b>Enercon Corona Treater</b>	<b>Listing #50280</b>	Width: 17", Approx. 88 print cylinders for a Propheteer 1700 press.	
Width: 18", Came off of a Mark Andy 4120 16" press, Watt Density Controller, TL Max, 2 Sided.		<b>Rapid Machine Core Cutter</b>	<b>Listing #50115</b>
<b>Flexcon F-30 Laminator</b>	<b>Listing #50198</b>	Manual core cutter, 1" cores no thicker than 1/4" wall, and 32" core length.	
Width: 30", Foot operated control, comes with extra rubber roll with new silicon, very good condition, and approx. from mid 80's.		<b>Rapid RG330 Sheeter</b>	<b>Listing #50243</b>
<b>Franklin 164 Hot Stamp Model</b>	<b>Listing #50089</b>	1996, Width: 12", Seperate unwind, three lineal slitter blades, Photo-Electric sensor/servo motor registration, Vacuum drum tension system, and programming disk included.	
1987, 1 Product Rewind, 1 Waste Rewind, Print station, Die station, shelter, and Laminator.		<b>Rapidline 17 Film Processor</b>	<b>Listing #50055</b>
<b>Gallus R160 Shingle</b>	<b>Listing #50020</b>	2000, Width: 17", Rapiline film processor & PC36 automatic film dispenser mfg by Mc Nulty Mfg.	
<b>Harper Ceramic Anilox Rolls</b>	<b>Listing #50086</b>	<b>Rotopress A02 Plate Mounter</b>	<b>Listing #50299</b>
Width: 16", Harper Anilox rolls used on a 16" Comco Proglide one time only, (2) 200 LPI 8 BCM, (1) 300 LPI 5.6 BCM, (1) 50 LPI 68 BCM, and (1) 160 LPI 10 BCM.		<b>Sanden Fan Folder</b>	<b>Listing #50005</b>
<b>Harper Ceramic Anilox Rolls</b>	<b>Listing #50196</b>	Approximately 1987. 1/8 Gearing, off-line unit, 5 1/2-18" repeat, 5 1/4" minimum fold, 17-18" maximum fold. Including running register, electronic preset and counter, electric drive, delivery belt & unwind with feed, and 20 extra gears to change fold length. In Good condition!	
Width: 6.5", (4) 60-800-2.0 BCM, (2) 60-100-1.0 BCM, from Webtron 650 - 1/8 Gearing 64 tooth, and in Excellent Condition!		<b>Seal-A-Tron S-3236 / T-3610</b>	<b>Listing #50273</b>
<b>Hoechst Celanese CF-262</b>	<b>Listing #50307</b>	2003, Width: 32", 32" x 36" L-bar sealer, loading table with roller bed infeed, Pacer film unwind (PFU)with adjustable inverter, 36" x 18" Varilocity shrink tunnel with GFN belt upgrade.	
Color Proofing Processor with Hot LaminatorWidth: 30", Wet Processor for Pressmatch and Matchprint color proofing materials.		<b>Shanklin A-26A Auto L-sealer with Shrink Tunnel</b>	<b>Listing #50314</b>
<b>Ikela Hot Stamp Unit</b>	<b>Listing #50036</b>	Width: 15", Length: 21", Fully automatic hot knife L-Sealer with T-7XL Shrink Tunnel capable of speeds up to 30 pkgs/min.	
1997, Width: 10", 1/8" Gearing, Used on a Comco, and Can be seen in operation.		<b>Sherwood Horizontal Wrapper CW-160</b>	<b>Listing #50050</b>
<b>Longford OS-700 Onserter</b>	<b>Listing #50315</b>	1988, Auto infeed indexer w/auto line synch, Rotary hot knife seal w/digital temp control, Rotary hot wire perf, Max speeds 80 packages/min, Max roll diam 13, Film requirements one roll, 3" core, single wound, and Package dims 3"- 18"L, 5" - 15"W, 1/4 - 4 1/4"H.	
2001, Width: 13", OBO, Includes Mark Andy based module. Triple motor surge feeder, eeds booklets to be applied to a moving web +/- .020" tolerance. Booklet size rom 1 5/8" x 4" up to 7" x 15". Affix upto 35,000 pieces per hour. Like-new condition, over \$130K new..		<b>Simco Nuetro DC 1200 Vac</b>	<b>Listing #50253</b>
<b>Mark Andy 82 Dryer Pack</b>	<b>Listing #50283</b>	460 VAC 3 Phase, HP 3, Power Supply and Screen only, In good working order.	
With intake and exhaust ducting to manifold, 230 VAC/3 Phase/ 36AMPS.		<b>Stevenson Shrink Wrapper</b>	<b>Listing #50052</b>
<b>Mark Andy 88 UV Curing Power Supply</b>	<b>Listing #50221</b>	Approx. Mid 1980's Model A-18, L-Seal, and Shrink tunnel 11" x 5.	
<b>Mark Andy 800 Chrome Anilox Roll</b>	<b>Listing #50161</b>	<b>Telstar Rotary Screen heads (2)</b>	<b>Listing #50206</b>
Width: 7"; 85 Quad engraving equal to 32 BCM.		Width: 16"; MISC- Repeat size Adapters.	
<b>Mark Andy 800 Series Print Stations</b>	<b>Listing #50245</b>	<b>Unisource Turbo Tunnel UT3422/10-LDR</b>	<b>Listing #50305</b>
Width: 7" and 5 print stations available.		1992, Width: 22", Length: 10", Heat Shrink Tunnel - 8 KW heater element with digital temperature controller, adjustable conveyor speed.	
<b>Mark Andy Accessory Stations</b>	<b>Listing #50294</b>	<b>Webtron 8000 Plate Mounter</b>	<b>Listing #50298</b>
Width: 16", frames, idlers, toggle switches, floor levelers, guards, drive shaft, air line extension (for ink pumps) and wiring harness, clean and in excellent condition.		Make an Offer.	
		<b>Webtron 8000 Plate Mounter</b>	<b>Listing #50201</b>
		Projection type plate mounter with extra grid pattern and from approx. Late 1970's.	
		<b>Webtron Laminating System</b>	<b>Listing #50276</b>
		Width: 18.5", 2 Upper Servo Driven Laminators, 2 Lower Servo Driven Laminators, 3	

## MISC. EQUIPMENT CONTINUED

Taper Tensioning Devices, 2 Non Driven Nip Rollers, 1 Crush Cut Lineal Slitting Unit, Fittings for Vacuum Waste Removal, Montalvo Driven Waste Capstan, North American Web Guide, 2 Overhead Bypass Towers, Simco Anti-StaticBars, Unit came off of Webtron 1618 Press, Equipment is excellent condition.

- Weldotron Shrink Wrap Machine** Listing #50051  
CL-28, 28" x 24" L-Sealing, 20" x 8" 700 degree heat tunnel with variable speed conveyor.
- Wilson Line Whole Punch Unit-1990** Listing #50252  
Fits Mark Andy 4300, 1/2"Centers, 1/8"Hole Size.
- Wilson Pinfeed Punch Unit** Listing #50067  
1992 model, Width: 16", Drop-in unit, and 1/8 Gearing. Very low usage; used only for 1 year!
- Wilson Pinfeed Punch Unit** Listing #50042  
1995 Like new, Width: 15", and Male/Female two ring punch unit; For a Allied Gear press.
- Webtron 650 Print Cylinders** Listing #50094  
Width: 6.5", Approx. 400 print cylinders, and 32 DP Gearing from 34 tooth to 120 tooth.
- Webtron 750 Chrome Anilox(s)** Listing #50211  
Width: 7.5", (3)400 Lines R27 Chrome 64 Tooth 20546"X 7.75", and (1)360 Lines R44 Chrome 64 tooth 2.546"X 7.75". All items sold as a package.
- Webtron 750 Stacker** Listing #50210  
No roller deck assembly and needs work!
- Webtron 8000 Plate Moulder** Listing #50271  
1980, Width: 6.5", Can see in Operation.
- Web Techniques WT-25 / Table Top Rewinder** Listing #50293  
2005, Width: 7", 3" OD mechanical unwind core holder, 3" OD pneumatic rewind coreholder, slitter assembly, 2 razor knife slitting blades.
- Weldotron 7221 Shrink tunnel & L-Bar Sealer** Listing #50285  
Width: 19" , Length: 15", Shrink Tunnel with 90 degree return, adjustable conveyor speed, variable velocity control & Lockdown rolling cart. L-bar sealer with adjustable dwell time control.
- Willet 460 Ink Jet Printing System** Listing #50312  
High quality printing of text, barcodes & Logos. High speed coding, lowest cost per code, push button start/stop with auto print head flushing, stainless steel IP54 Cabinet.
- Wooden Core Adapter** Listing #50166  
3" to 5" core adapter to be used on existing 3" pneumatic Core holder,max web width of 10", and durable hardwood with industrial rubber o-rings.

## UV SYSTEM

- Aetek UV System** Listing #40006  
1992 UVXL100137A, Width: 10", and 700 w metal halide without exhaust blowers.
- Brewer 300-Watt UV Curing System** Listing #40038  
1985, Width: 7", 1 Dual Lamp.
- Eye Ultraviolet 400-Watt UV Curing System** Listing #40039  
1997, Width: 10", 2 Single Lamps, 3-Stage, 230-Voltage, 50 amps, Electric Quick Disconnect, Includes "Cool" UV Lamp Assembly, Exhaust Blower & Controller.
- F300M-18 UV Curing System** Listing #40029  
Width: 24", Can be seen in Operation. F300 lamps with the transformers, Irradiator Assembly, DRS-310, F300 Sys, Adj focus, and 12" long table.
- Honle UV System** Listing #40019  
Width: 10", Four lamp cold mirror or UV system with, 2 lamps at 400 wpi, 2 lamps at 600 wpi, Variable power from 30%/100%, Remote control, and 10" wide max web.
- IST - 400 Watt UV Curing System** Listing #40026  
1999, Width: 8", 3 Single Lamps, 3 Lamp cartridge with auto dampners, exhaust fans and control panel.
- Lightouch Versiflex / 400-Watt UV Curing System** Listing #40040  
2003, Width: 14", 6 Single Lamps, 5-Stage, Auto Ramp Wattage Adjustment, Manual Ramp Wattage Adjustment, PLC Control, 230-Voltage, 140 amps, Electric Quick Disconnect, 4" Flex Duct from Lamp to Power Supply,Includes Side Load, flip-top, clamshell lamp cassettes, closed-loop variable speed exhaust blowers, programmable touch screen remote control and six station electronic control cabinet.
- Tech Lighting UV Curing System** Listing #40036  
Width: 7", 6 Single Lamps, System designed for 7" Mark Andy 2100, combination UV and hot air dryers, System has never been installed.
- UV Research 5019 400-Watt UV Curing System** Listing #40037  
2003, Width: 16.5", 9 Single Lamps, 3-Stage, Auto Ramp Wattage Adjustment, Manual Ramp Wattage Adjustment, PLC Control, 460-Voltage, 150 amps, 4" Flex Duct from Lamp to Power Supply, Exhaust Plenum, Clamshell Style Lamp Head Mounting. Upgraded PLC program in 2007.
- UV Research UV Curing System** Listing #40021  
1998 400 w, Width: 10", 4 Station,blowers, ducting, and controls.
- UVT 400-Watt UV Curing System** Listing #40032  
Width: 11.5", 6 Single Lamps. Power supply, trimline lamp cassettes, and No blowers.

# LIGHT TOUCH™

## \* UV CURING SYSTEMS



## Harness the Power

Outstanding proven performance with over 3,000 installations. Compact retrofitable lamp cassettes... Unmatched support backed by a comprehensive 2 yr/2,000hr warranty.



**AAA Press International, Inc.**

Equipment

# New Products

## ⇒ NEW LINEAR LED Stroboscope Model DT-329

All new linear stroboscope product employs the outstanding brightness of LED technology.

### Feature:

- High flash rate - 120,000FPM (2,000Hz)
- High brightness - 1,950 lux at 120,000FPM and 7.87in (20cm)
- Wide flash area - about 23.62in x 15.75in (600mm x 400mm)
- 5 X life over xenon tube technology
- Quick setup - the flash rate can be easily changed with the jog dial
- Optional input synchronization & AC cables available



**NOW ONLY:** \$2,300.00

# Press Room Accessories

## ▷ AAA Sure-Count Totalizer

Accurate print counter of production throughput includes digital counter output, simple reset feature, and management security key lock.

### FEATURES:

- Digital touch pad interface
- Key lock reset
- Total & job feet counter
- Microprocessor controlled



### Digital Printing Counter

Was: \$975.00

**NOW: \$899.00**



Toll Free: + 1 800 678 7222 or Int'l: + 1 847 818 1100

## ▷ megaMAG™ For Superior Protection Against Anilox Scoring/damage

megaMAG can save the time required to pull a damaged anilox roll out of service.

### FEATURES:

- A rare earth magnet in a smooth stainless steel casing, with 10x the pulling power of a standard magnet, megaMAG is able to attract metal particles from any place within the filter body.
- Unlike other rare earth magnets, megaMAG's domed end is designed to easily release particles when cleaning.

megaMAG is available for use in a Superflo filter (HFST or HFNT).



Filter Lid Mount  
# MEGAMAG-FLM  
**NOW: \$152.00**



Bracket Mount  
# MEGAMAG-BM  
**NOW: \$22.50**

## ⇒ Static Control String & Tinsel

The Lowest Cost Solution to Static Electricity Problems in Converting, Packaging, Textiles, Plastics and Electronic Operation.

 + 1 800 678 7222



**Anti-static String**

#AAA-10102 **NOW: \$65.00**



**Anti-static Tinsel**

#AAA-10101 **NOW: \$25.50**

## Slitter / Perforating Blades

**WHILE QUANTITIES LAST!**

Parts #	Description	Qty	List Price	Special
#93-4235	Perf Blade - 6 Teeth Per Wheel - 1/16" Tie - 7/8" Bore	1	\$40.00	<b>\$29.00</b>
#93-4220	Perf Blade - Lineal - 12 TPI - 7/8" Bore	3	\$44.00	<b>\$32.00</b>
#93-4225	Perf Blade - Lineal - 4 TPI - 7/8" Bore	2	\$32.00	<b>\$24.00</b>
#93-4224	Perf Blade - Lineal - 8 TPI - 7/8" Bore	3	\$38.00	<b>\$28.00</b>
#93-4230	Perf Blade - Lineal - 25 TPI - 7/8" Bore	1	\$31.00	<b>\$24.00</b>
#93-4229	Slitter Blade - Lineal - 35 TPI - 7/8" Bore	4	\$34.00	<b>\$28.00</b>
#4001-3/8-R	Slitter Blade - 3/8" Radius - 3/4" Bore	2	\$15.50	<b>\$12.00</b>

## Strobe Components

**WHILE QUANTITIES LAST!**

Parts #	Description	Qty	List Price	Special
#04-01427	Trigger Connector - Cable Pulse	1	\$50.00	<b>\$38.00</b>
#04-1380	Unilux Strobe Swivel Mount - Vertical - Table	2	\$63.00	<b>\$51.00</b>
#05-1302	Lamp Holder Assy - Press In	2	\$60.00	<b>\$50.00</b>
#05-1534	Handle - Cricket Strobe - Unilux	1	\$31.00	<b>\$25.00</b>
#41-7410-C	PC Industries - Potentiometer	2	\$60.00	<b>\$48.00</b>
#56-1006	Mount Bracket - Clamp - Unilux Strobe	4	\$9.75	<b>\$8.75</b>
#59-4243	Strobe Arm Base - With Clamp	8	\$15.50	<b>\$10.25</b>
#59-4250	General Radio - Strobe Lense Cover	2	\$22.00	<b>\$15.00</b>
#99-7015-A	General Radio - Strobe Lense	4	\$35.00	<b>\$25.00</b>
#59-4230	On / Off Switch - AAA / PC Strobe	1	\$55.00	<b>\$45.00</b>
#DT-311-F	Shimpo - Strobe Fuse	2	\$5.00	<b>\$4.00</b>
#DT-314-C	Shimpo - Connecting Cable 311/314	1	\$62.00	<b>\$45.00</b>
#FPM-6	Shimpo - Tachometer Measuring Wheel - 6"	1	\$55.00	<b>\$32.00</b>
#59-4238-U	HD Strobe - Highlighter - Used	1	\$665.00	<b>\$550.00</b>
#59-4247-S	HD Strobe Base with Swivel	1	\$42.00	<b>\$35.00</b>
#05-1534	Handle - Unilux Cricket Strobe	1	\$31.50	<b>\$26.00</b>

**AAA PREES CAN REPAIR YOUR STROBES ECONOMICALLY!!**

## ■ Lith-O-Light 20 - Web Strobe Light

Improves quality control by lighting the entire web width (up to 1.1 meters).



**Lith-O-Light 20 - Inspection Light**  
#LOL-20-3600 **NOW: \$3,650.00**

### SYSTEM FEATURES:

- Outstanding brightness
- Even light spread eliminates hotspot
- Long lamp life
- External & internal strobe triggers

## ■ WT-25 LCI Rewind Table

Synchronized strobe light for high-speed visual inspection.

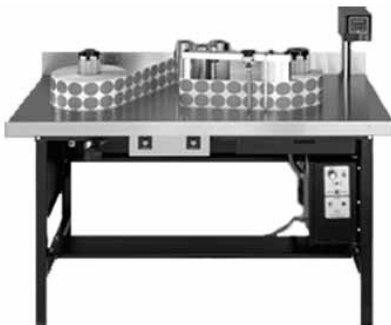

Model WT-25 LCI

### FEATURES:

- Strobe light flashes with each label
- Count individual labels or by length
- Pedestal-mounted high-visibility counter
  - ... *Dual Preset.* Set deceleration and stop points.
  - ... *Large.* Bright red LED display.
  - ... *Counts in 10-inch increments* (12-inch or metric increments optional).
  - ... *Automatic Reset to Zero in length mode.*
  - ... *Automatic Bi-Directional Counting* (counts down automatically).
  - ... *EEPROM Memory.* Retains data with power off.
- Oversized table top with extra web length
- Razor blade slitting attachment available
- Reversible rewind- wind labels in or out
- Adjustable brake to control web tension
- Choice of core holder style (lift-off Cam-lock or air inflatable)

## ■ Accu-Web Guide

A cost effective solution for narrow web applications.



### Example:

**AccuGuide for Mark Andy 810/820/830**  
#AB-9829 **NOW: \$2,995.00**

**Proprietary Linear Bearing System** — Cam follower bearings run in a hardened track to reduce friction and wear, allowing for a faster, more accurate response.

**Simple, Drop-in Installation** — Optional cantilevered brackets and guide mounted or remote mounted switch pads provide fast, trouble-free installation.

**Free-turning Idler Rollers** — Free-running bearings minimize rotational torque – ideal for running light webs. Dynamically balanced rolls ensure vibration-free performance.

**Projected Pivot Point** — The unique bearing system is designed to position the pivot point exactly on the incoming web plane to ensure guide accuracy.

## ■ Static Clean Web Vac System

The **Web Vac Cleaning System** is a continuous-duty cleaning system designed to provide contact or non-contact cleaning of narrow and wide webs in a variety of critical applications.



### Innovative design...

- Increase profits- reduces waste, even when using water-based inks!
- Fewer machine shutdowns; affordable and economical
- Easy to install, easy to operate; reduces maintenance requirements
- Reduces re-contamination of the web

# Replacement Parts

## Arpeco Blades



### Arpeco Female Assembly

#A-106071

**NOW: \$83.00**



### Arpeco Male Assembly

#A-106073

**NOW: \$83.00**



### Arpeco Dish Assembly

#A-10675

**NOW: \$62.50**

## SPRAYWAY PRODUCTS WHILE QTYS LAST!



12 CANS PER CASE

List: \$88.00

**Now: \$69.00**

**ALSO 10% OFF ALL  
OTHER SPRAYWAY  
PRODUCTS!**

## OVERSTOCKED INVENTORY BLOWOUT

### LIMITED TO IN-STOCK QUANTITIES!

Parts #	Description	Now
#368-300-P	Anilox Roll - Chrome - Web 650 - 150 PYR - 1/8	\$325.00
#650-32	Anilox Roll - Ceramic - Web 650 -32 DP (60-200-10.0)	\$450.00
#650-1/8	Anilox Roll - Ceramic - Web 650 - 1/8-64 60-550-4.5	\$450.00
#820-7-QC	Anilox Roll - Ceramic - Mark Andy 830 -7" - 60-360-5.0	\$625.00
#COM-1300/H	Anilox Roll - Comco Commander 13" - 60-800-3.0	\$1,200.00
#PROPH-700	Anilox Roll - Propheteer 700 7" - Choice of Engraving	\$545.00
#PROPH-1700	Anilox Roll - Propheteer 1700 17" - Choice of Engraving	\$1,225.00
#AD-800	Airdale Dryer 8" with Controller	\$940.00
#03839001	Converttech Coreholder - Unwind Mark Andy 4120 16"	\$950.00
#51M005	Converttech Coreholder - Rewind Mark Andy 4120 16"	\$625.00
#99-4240-10	Converttech Coreholder - Unwind Mark Andy 4120 10"	\$475.00

## STROBE LAMPS



### Shimpo Digital

#DT-311

**NOW: \$525.00**



### Unilux Cricket

#03-1159

**NOW: \$420.00**



### PC Highlighter

#59-4238-HD

**NOW: \$665.00**

**DID YOU KNOW THAT...** AAA Press International has an abundant amount of replacement parts that are overstocked and drastically reduced in price. Give us a call at 800.768.7222 or 847.818.1100

## STATE-OF-THE-ART Converting Technologies

**AAA Press International** is the premier supplier to the label, tag, carton & flexible packaging industries offering products from presses to replacement parts. We have been providing world-class service to over 1,800 customers for more than 21 years. Our dedication and mission is to continue partnering with converters by offering the very best converting products and solutions at below market prices with un-matched service and support.

**LIGHTTOUCH™**



\*Versiflex... \*Microstep... \*Pro-cure

AAA Press is the proud manufacturer of Lighttouch UV curing systems with more than 3,000 lamps in the field installed in virtually every UV application in the converting industry.

### Motorized Portable Roll Lifter

**e-lift**

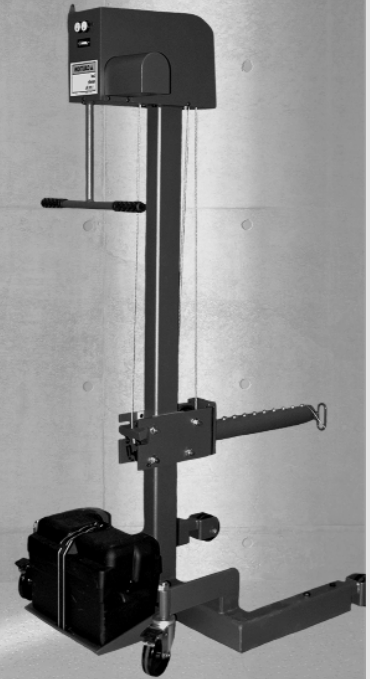

” Providing the best solutions for  
... your growing business ”



**MAXIMIZER™**

Infra-red Drying Systems

The Maximizer IR Drying System is manufactured in 4-bulb, 6-bulb and 9-bulb configurations & is easily retrofit on to existing equipment or seamlessly integrated on to new OEM presses. The unique impinged air system delivers outstanding drying capacity to a moving web.



AAA Press International, Inc.

US & Canada 800-678-7222 | Int. 847-818-1100 | Fax 847-818-0071 | [www.aaapress.com](http://www.aaapress.com)



## RL-1000 Portable Roll Lifter

The I-Lift RL-1000 is ideal for lifting and loading rolls on & off presses, rewinders & converting equipment. The versatile I-Lift is built tough for trouble free roll lifting and is manufactured using only the highest quality materials.

This rugged roll lifter is an all-steel, ergonomic roll lifting device that offers a smooth reversible crank-style winch, low-inertia casters, simple detachable core lift boom and ideal height operator handles allowing operators to stand upright while raising, lowering, transporting & loading rolls, reducing the probability of personal injury. The low friction wheels and optimal footprint make moving rolls around the shop floor a snap. The I-Lift is equipped with a dual safety brake and requires very little maintenance.

### Features:

- Extendable legs for different roll widths and loading positions
- Durable roller-ball boom with safety pin for loading, unloading & transporting rolls
- Zero-turn radius for maneuvering rolls in tight places
- Automatic safety brake on boom carriage
- Reversible crank-style winch with automatic load brake
- All steel construction for longevity and worry-free operation

### Specifications:

- 950 pound maximum roll lifting capacity
- Use with 3" or 6" ID cores
- 16" maximum roll width
- 40" maximum outside roll diameter
- 56" maximum core lift height

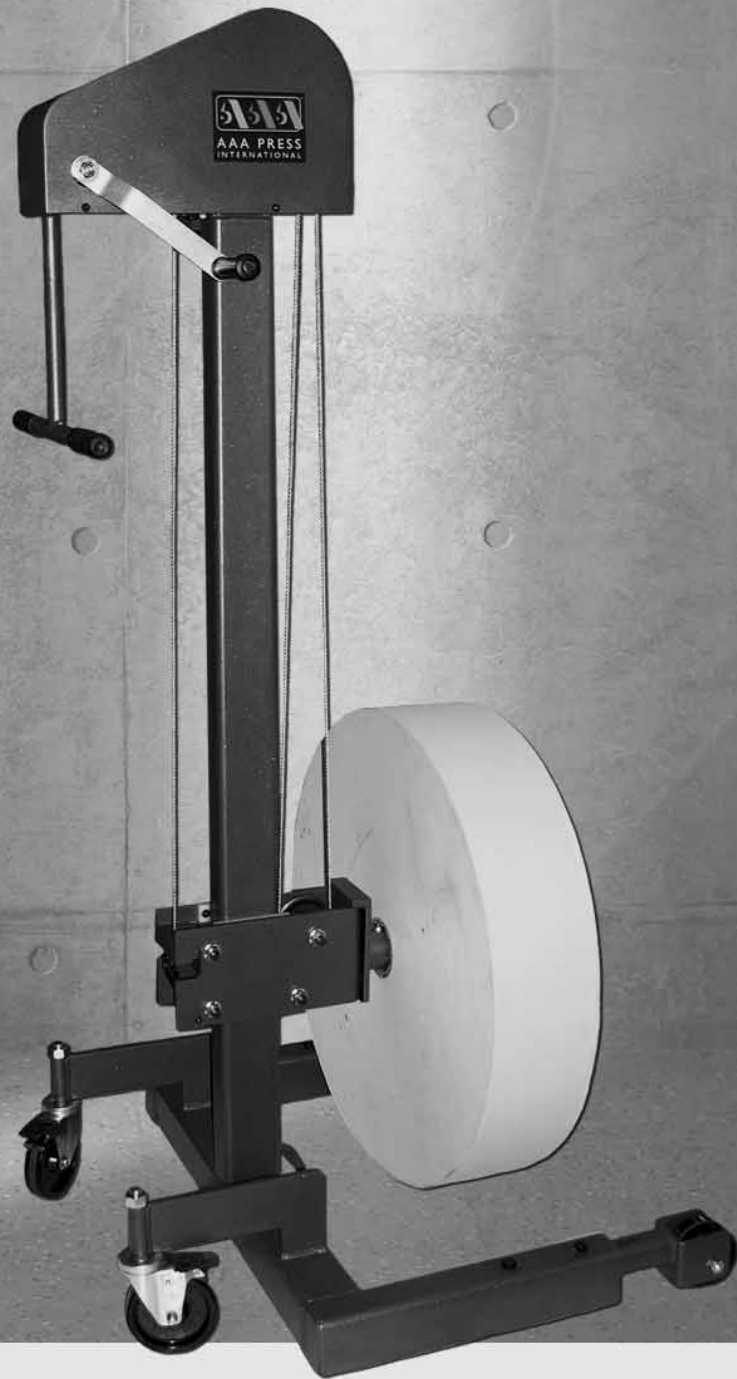

 AAA Press International, Inc.

US & Canada 800-678-7222 | Int. 847-818-1100 | Fax 847-818-0071 | [www.aaapress.com](http://www.aaapress.com)

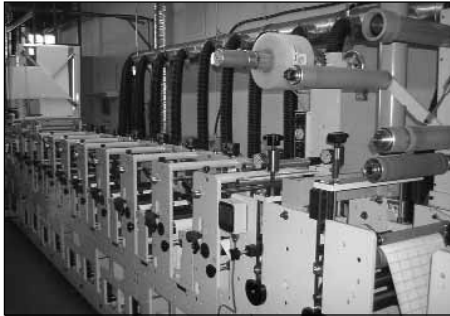

## PRESS OF THE MONTH

### Mark Andy 2200 / 10-color

2005, Width: 13", 1/8" Gearing, 24" Print Repeat, Automatic Throws / Constant Turn Anilox Rolls, 10 Quick Change Anilox Assemblies, 10 Dr. Blade Assemblies, 2 Product Rewinds, 40" Rewind Diameter, 2 Waste Rewinds, 1 Unwind, 40" Unwind Diameter, 2 Die Stations, 24.000" Die Repeat, 3 Removable Base Rolls, 1 Sheeting Station, 1 Laminator, 1 Electronic Edge Guide, 1 Turn-bar, 1 UVT 400-WPI Single-Lamp UV Unit, 1 Video Web Inspection System, Cold Foil Stamping, Approx. 11 Ceramic Anilox Rolls, Approx. 183 Plate Cylinders, Can see in Operation. MINT CONDITION... LIKE NEW with 9 Infra-red Dryers, integrated roll lifter, integrated die lifter, (2) Hydrjack die pressure guages, & all exhaust ducting.

[Listing #10644](#)



## EQUIPMENT OF THE MONTH

### Anderson Vreeland Orbital X / Orbital Plate Maker

2006, Length: 12", Width: 18", Flexo, Exposure, Water Washout, Dryer, 3 Drying Drawers, Detach, Mint...Like New Condition.

[Listing #30081](#)

**The Dependable One Stop Complete Flexo Shop for Equipment Brokerage, IR Drying / UV System, Parts & Service!**



**AAA Press International, Inc.**

3160 N. Kennicott Ave.  
Arlington Heights, IL 60004

Return Service Requested

FIRST CLASS MAIL  
U.S. POSTAGE  
**PAID**  
PALATINE P & DC, IL 60095  
PERMIT NO. 2401